

CITY OF KELOWNA

BYLAW NO. 10640

Amendment No. 15 to Subdivision, Development and Servicing Bylaw No. 7900

A bylaw to amend the "City of Kelowna Subdivision, Development and Servicing Bylaw No. 7900".

The Municipal Council of the City of Kelowna, in open meeting assembled, enacts that City of Kelowna Subdivision, Development and Servicing Bylaw No. 7900 be amended as follows:

1. THAT PART 1 - INTRODUCTION, 4.0 Definitions, be amended by deleting the definition name "Excavation Permit" and replacing it with "Road Usage Permits" and that all references to Excavation Permit be deleted and replaced with Road Usage Permits;
2. AND THAT PART 5 - OWNER TO PERFORM WORK, 9.4 Construction Requirements , sub-paragraph (i) Traffic be amended by adding to the end of the paragraph the following:

"For any disruptions to traffic on a right of way including pedestrian sidewalks, bike lanes and pathways, traffic control plans(s) are required as part of Road Usage Permit approval process."
3. AND THAT SCHEDULE 4 OF BYLAW 7900 CITY OF KELOWNA DESIGN STANDARDS, title page be deleted in its entirety and replaced with a new SCHEDULE 4 OF BYLAW 7900 CITY OF KELOWNA DESIGN STANDARDS, title page as attached to and forming part of this bylaw as Appendix 'A';
4. AND THAT SCHEDULE 4 DESIGN STANDARDS, 1. WATER be amended by:
 - a) in 1.2 Per Capita Demand , delete the words "Peak daily flow 2400 litres/capita/day" and replace it with "Peak daily flow 1800 litres/capita/day";
 - b) in 1.3 Fire Flow Demand, delete the sentence:

" The following minimum fire flows must be met for the noted zones under peak daily flow conditions:"

and replace with:

"For all new subdivisions or upgrade of the existing watermains, the following minimum fire flows must be met for the noted zones under peak daily flow conditions:" and "For existing lots, the buildings must conform to the British Columbia Building Code's Fire Protection Requirements:"
5. AND THAT SCHEDULE 4 DESIGN STANDARDS, 2. SANITARY SEWER be amended by:
 - a) in 2.2 Design Flows, sub-paragraph (f) that reads:

"Pipes shall be designed so that sewers flow 2/3 full for pipes 250 mm diameter and less, or 3/4 full for pipes greater than 250 mm diameter" be deleted and replaced with;

"Pipes shall be designed so that the sewer flow does not exceed $d/D=0.67$ for pipes 250 mm diameter and less, or $d/D=0.75$ for pipes greater than 250 mm diameter. {d=flow depth and D=pipe diameter}."

b) in 2.4 Manholes, deleting the following:

“Manholes are required at:

- all changes in grade
- all changes in direction
- all changes in pipe sizes
- all intersecting sewers
- all terminal sections
- downstream end of curvilinear sewers

Manholes must be placed where future extensions are anticipated and must be spaced no greater than 150 m apart.”

and replacing it with:

“Manholes are required at:

- All changes in grade
- All changes in direction
- All changes in pipe size
- All intersecting sewers
- All terminal sections
- Upstream and downstream end of curvilinear sewer mains

Manholes must be placed where future extensions are anticipated and must be spaced no greater than 150 m apart.

Placement of manholes in existing or future wheel paths is to be avoided”

6. AND THAT SCHEDULE 4 DESIGN STANDARDS, 2. SANITARY SEWER be amended by deleting in Section 2.5 Hydraulic Losses Across Manholes, sub-paragraph (a) that reads:

“The springline of the downstream pipe must not be higher than the springline of the upstream pipe”

and replacing with:

“The crown of the upstream pipe must not be lower than the crown of the downstream pipe. When connecting a collector sewer main to a trunk sewer 300mm or greater, the invert of the collector main must not connect lower than 0.75D (3/4 of the pipe diameter).”

7. AND THAT SCHEDULE 4 DESIGN STANDARDS, 2. SANITARY SEWER be amended by deleting in Section 2.9 Minimum Grade that reads:

“The grade of any sewer is governed by the minimum velocity required of 0.6 m/sec. If the calculated design flow is not expected to produce a velocity of at least 0.6 m/sec., then the minimum grade shall be calculated on the basis of the pipe flowing 35% full at a theoretical velocity of 0.6 m/sec. However, the last section of a main that will not be extended in the future, must have a minimum grade of 1.0% where 150 mm diameter pipe is proposed.”

and replacing it with:

“The grade of any sewer is governed by the minimum velocity required of 0.6 m/sec. If the calculated design flow is not expected to produce a velocity of at least 0.6 m/sec., then the

minimum grade shall be calculated on the basis of the pipe flowing 35% full at a theoretical velocity of 0.6 m/sec."

8. AND THAT SCHEDULE 4 DESIGN STANDARDS, 2. SANITARY SEWER be amended by deleting in Section 2.10 Depth and Cover the sentence that reads:

"The absolute minimum cover over a pipe must be 1.0 m (measured from the surface to the top of pipe)."

and replacing it with:

"The absolute minimum cover over a pipe must be 1.2 m (measured from the surface to the top of pipe)."

9. AND THAT SCHEDULE 4 DESIGN STANDARDS, 2. SANITARY SEWER be amended by:

- a) deleting in Section 2.13 Service Connections, sub-paragraph (k) that reads:

"(k) Inspection Chambers (I.C.'s) are required for all service connections, except when the sewer main is in a right-of-way and the service is less than 2.5m long and ties into a manhole."

and replace it with:

"(k) Inspection Chambers (I.C.'s) are required for all service connections, except when the sewer main is in a right-of-way and the service is less than 2.5m long and ties into a manhole. Brooks Boxes are to be installed on every inspection chamber."

- b) adding in Section 2.13 Service Connections, a new sub-section (o) as follows:

"(o) Service connections must be installed at least 0.5m horizontally from the water service and a minimum of 1.5m from any side lot line."

10. AND THAT SCHEDULE 4 DESIGN STANDARDS, 2. SANITARY SEWER be amended by:

- a) deleting in Section 2.15 Force Main, the following:

"In conjunction with sanitary pumping facilities, the following criteria must be noted in the design of force main systems: Design computations for force mains must be made using a 'C' factor of 120 (for PVC pipe) and then re-calculating the system curve using a 'C' factor of 145 to ensure adequate motor horsepower and pump characteristics."

And replacing it with:

"In conjunction with sanitary pumping facilities, the following criteria must be noted in the design of force main systems: Design computations for force mains must be made using a 'C' factor of 120 (for PVC pipe) and then re-calculating the system curve using a 'C' factor of 145 to ensure adequate motor horsepower and pump characteristics. Show pump and system curves on design drawings."

- b) deleting in Section 2.15 Force Main, Air Relief Valve, sub-paragraph (b) that reads:

"An automatic air relief valve must be placed at high points in the force main to prevent air locking."

and replacing it with:

"A combination automatic air/vacuum relief valve must be placed at high points in the force main to prevent air locking when the difference in elevation between the invert of the summit and the invert of the valley is greater than the diameter of the pipe. The air relief valve must be located in a chamber, complete with adequate and environmentally safe drainage and odour control, unless a suitable injected odour control agent is used at the Lift Station. Air valve must be vented and drained into the gravity sanitary sewer system at a manhole, where possible."

- c) deleting in Section 2.15 Force Main, Termination, sub-paragraph (c) that reads:

"Force mains should enter the gravity sewer system at a point not more than 600 mm above the flow line of the receiving manhole. An inside drop pipe must be incorporated. If the receiving manhole design does not allow this, then a manhole drop structure in accordance with the standard drawings, is required."

and replacing with:

"Force mains should enter the gravity sewer system so that the forcemain invert is not more than 200 mm above the crown of the pipe in the receiving manhole. A smooth, turbulent free transition must be incorporated. If the receiving manhole design does not allow this, then a manhole drop structure in accordance with the standard drawings is required."

- d) deleting in Section 2.15 Force Main, Materials, sub-paragraph (e) that reads:

"With the exception of valves, the material selected for force mains must meet the standards specified for water mains and in accordance with Schedule 5 and must adapt to local conditions, such as character of industrial wastes, soil characteristics, exceptionally heavy external loadings, abrasion and similar problems.

Valves used on force mains shall be lubricated plug valves sufficient for long term use in a corrosive environment."

and replacing it with:

"Force mains must generally meet the standards specified for water mains and in accordance with Schedule 5, however there are specific requirements for force mains that may supersede water main standards, as follows:

- Force main pipe must be identifiably different than water main pipe and should be white in colour (refer to supplemental specifications 5.1 Section S02732).
- Valves used on force mains and pigging ports or cleanouts shall be lubricated full port plug valves size on size sufficient for long term use in a corrosive environment."

- e) deleting in Section 2.15 Force Main, Loads and Transient Pressures, sub-paragraph (f) that reads:

"All force mains must be designed to prevent damage from superimposed loads, or from water hammer or column separation phenomena."

And replace with:

"All force mains must be designed to prevent damage from superimposed loads. Must also be designed to prevent damage from water hammer or column separation

phenomena. Transient surge and cyclic surge analysis must provide at least a 75 year life of the pipe.”

- f) deleting in Section 2.15 Force Main, Corrosion and Odour, sub-paragraph (g) that reads:

“Corrosion and Odour controls may be required.”

and replace with:

“Corrosion and Odour control is required when limited daytime flows, or long force main lengths cause the pumped sewage to remain in the force main for longer than 45 minutes.”

- g) adding in Section 2.15 Force Main, a new sub-paragraph **Pigging Port** (h) that reads:

“Pigging Port

- (h) A “size on size” pigging port that is convenient for the City Operations to use and maintain must be incorporated in the forcemain outside of the Lift Station.”

- 11. AND THAT SCHEDULE 4 DRAINAGE, 3.2 MINOR SYSTEM DESIGN, sub-section Manholes be amended by adding to the end of the section the following:

“Placement of manholes in existing or future wheel paths is to be avoided.”

- 12. AND THAT SCHEDULE 4 DRAINAGE, 3.3 MAJOR SYSTEM DESIGN, sub-section Culvert and Bridge Capacity be deleting the following that reads:

“Culvert and Bridge Capacity

The following service levels are to be used for design:

<u>Road Class</u>	<u>Design Flood Frequency Bridges, Culverts</u>
Arterial and Collector	1:200 year flood
Local	1:100 year storm plus provision for overflow if on major channel

Culverts over 30 m in length and/or 300 mm and larger in diameter shall be constructed with headwalls and endwalls. The headwall shall be constructed with a free swinging, weighted grating. To protect against entry, the City may require a locking mechanism which limits the range of movement of the grating.”

and replacing it with:

“All culverts (or pipes with inlets or outlets), unless specified in table below, shall be constructed with headwalls & endwalls. The headwalls & endwalls shall be constructed with a free swinging, weighted grating. To protect against unauthorized entry, a locking mechanism which limits the range of movement of the grating is required.

Pipe & Culvert Table

Pipe Length	Pipe Diameter	Headwall	Endwall ²	Grillage ¹	Reinforced Concrete Collar ²
<20m	=<450mm				✓
<20m	>450mm	✓	✓	Inlet	
>20m	<450mm	✓	✓	Inlet	
>20m	=>450mm	✓	✓	Inlet & Outlet	
Any	=>450mm with intersections	✓	✓	Inlet & Outlet	

¹ Grillage, as per, MMCD S13

² Endwalls and collars, as per, MMCD S14 & S15.

Culverts (or pipes) discharging perpendicular to a watercourse may use alternatives methods to protect the end of pipe; provided, they are approved by the City Engineer."

13. AND THAT SCHEDULE 4 DRAINAGE, TABLE 2 - IDF CURVE VALUES for 1 HOUR STORM be deleted in its entirety and replaced with a new TABLE 2 - IDF CURVE VALUES for 1 HOUR STORM as attached to and forming part of this bylaw as Appendix 'B';
14. AND THAT SCHEDULE 4 DRAINAGE, TABLE 3 - HYETOGRAPHS be deleted in its entirety and replaced with a new TABLE 3 - HYETOGRAPHS as attached to and forming part of this bylaw as Appendix 'C';
15. AND THAT SCHEDULE 4, 5. ELECTRICAL, ELECTRICAL, STREET LIGHTING AND COMMUNICATION WIRING, be amended by adding a new sub-section 5.6 Kiosks/Laminate Wrapping Requirements as follows:

"5.6 Kiosks/Laminate Wrapping Requirements

All kiosks to be wrapped with anti graffiti vinyl wrapping. Wrap material shall be a cast vinyl then laminated with a high gloss laminate. The wrap is to be visually pleasing and compliment the area it would be situated in considering the landscape, geography, or general theme of the specific area. Artwork to have a high degree of contrast so as to be more impervious to graffiti vandalism and not to be for commercial advertising. All artwork to be approved before installation."

16. AND THAT SCHEDULE 4, 7. HILLSIDE STREET STANDARDS, be amended by deleting "7. HILLSIDE STREET STANDARDS" and replacing it with "7. HILLSIDE DEVELOPMENT STREET STANDARDS" and that all references to "Hillside Street Standards" be deleted and replaced with "Hillside Development Street Standards";
17. AND THAT SCHEDULE 4, 7. HILLSIDE STREET STANDARDS, 7.1 General be amended by deleting the following:

"Where development lands receive hillside ("h") zoning, these standards may be utilized in place of the specific sections in the HIGHWAY DESIGN STANDARDS (Section 4 of this Schedule). The Hillside Street Standard drawings are included in Schedule 5, Section 2 (Drawings) of this Bylaw."

And replacing it with:

"Where development lands receive hillside zoning (Residential Hillside (RH) zone or "h" designation to parent RU1 zone), these standards may be utilized in place of the specific

sections in the HIGHWAY DESIGN STANDARDS (Section 4 of this Schedule). The Hillside Street Standard drawings are included in Schedule 5, Section 2 (Drawings) of this Bylaw."

18. AND THAT SCHEDULE 4, 7. HILLSIDE STREET STANDARDS, 7.2 Street Trees be amended by deleting the following:

"Street trees and landscaping are to be to the satisfaction of the Parks Department."

And replacing it with:

"Street trees and landscaping are to be to the satisfaction of the City's Development Services Department/Subdivision Approval Branch and a landscape plan showing proposed planting on private property are required. The City's Development Services Department/Subdivision Approval Branch will require a performance bond for landscaping on private property."

19. AND THAT SCHEDULE 4, 7. HILLSIDE STREET STANDARDS, 7.3.8 Cul-de-Sac Streets and Hillside Emergency Accesses, *Cul-de-sac*, be amended by deleting the title ", 7.3.8 Cul-de-Sac Streets, Hillside Emergency Accesses and Hillside Private Lanes";

20. AND THAT SCHEDULE 4, 7. HILLSIDE STREET STANDARDS, 7.3.8 Cul-de-Sac Streets, Hillside Emergency Accesses and Hillside Private Lanes be amended by:

a) deleting the bullet:

- "A secondary emergency access must be provided for all public cul-de-sac streets that are in excess of the maximum length as specified by the City of Kelowna."

And replacing it with:

- "A secondary emergency access must be provided for any public cul-de-sac streets that are in excess of the maximum length as specified by the City of Kelowna. This requirement may be modified with the written approval of the City's Development Engineering Manager or Subdivision Approving Officer."

b) Adding the following after the section titled **Hillside Emergency Access** as follows:

"Hillside Private Lanes/Emergency Access Lanes/Maintenance Roads

Maximum grade: 15%;

Private Lanes must have a turn-around at or near their terminus. Acceptable turn-around types include cul-de-sac, eyebrow or hammerhead.

6.0m ROW; 6.0m roadway"

21. AND THAT SCHEDULE 4, 7. HILLSIDE STREET STANDARDS, be amended by adding a new sub-sections **7.3.9 Lighting Standards** and **7.3.10 Sanitary Sewer Location and Corridors** in appropriate location as follows:

"7.3.9 Lighting Standards

Allow for reduced light pollution where street lighting may be visually prominent.

7.3.10 Sanitary Sewer Location and Corridors

Where rear yard sewers are necessary, ROW of for rear yard serviced lots must be constructed in a manner which allows for practical and unencumbered access by maintenance equipment with a minimum width of 4.5m with a grade of less than 15%.

Vehicle access to manholes is required and these accesses are to be protected by a right-of-way which would be perpendicular to the road.

In order to help reduce the number of required manholes around a curve, manufactured long radius bends may be used to achieve curves, if approved by the City Engineer. The following standards should apply:

1. Maximum of 3 bends between manholes.
2. Minimum of 1 full pipe length (4m) between each bend.
3. All bends shall be supplied by an approved pipe manufacturer as listed in the City's approved products list.
4. All bends shall be a 'long radius bend'.
5. Maximum bend angle of 11.25 degrees.
6. Minimum pipe diameter of 200mm.
7. The resulting pipe alignment shall have a constant radius (i.e. no compound or reverse curves) which shall be noted on the design & as-built drawings. If bends are to be installed within a roadway, the radius for the pipe alignment shall have a constant offset from the road centreline or edge of curb.
8. Manholes must be installed within 10m of each end of the resulting equivalent radius.
9. The minimum pipe grade shall be governed by a minimum design velocity of 0.9 m/s. If flows of 0.9m/s are not expected, than the minimum grade shall be calculated based on the pipe flowing 35% full at 0.9m/s. However, in any case, the minimum grade shall not be less than 1%.
10. The as-built drawings shall detail the co-ordinates of each bend location."

22. AND THAT SCHEDULE 4, 7. HILLSIDE STREET STANDARDS, TABLE 1 - HILLSIDE STREET STANDARDS be deleted in its entirety and replaced with a new SCHEDULE 4, 7. HILLSIDE DEVELOPMENT STREET STANDARDS, TABLE 1 - HILLSIDE DEVELOPMENT STREET STANDARDS as attached to and forming part of this bylaw as Appendix 'D' ;

23. AND THAT SCHEDULE 4, 7. HILLSIDE STREET STANDARDS, TABLE 2 - ALIGNMENT DESIGN CRITERIA be amended by deleting the following:

1. Horizontal Curve Radii				
Criteria	60 km/h	50 km/h	40 km/h	30 km/h
Roadway Crossfall				
normal crown (-2%)	260m	165m	90m	45m
2% superelevation	205m	120m	65m	30m
4% superelevation	150m	80m	45m	22m
6% superelevation	120m	-	-	-
Through Intersections	200m	120m	70m	40m

And replacing it with:

1. Horizontal Curve Radii				
Criteria	60 km/h	50 km/h	40 km/h	30 km/h
Roadway Crossfall				
normal crown (-2%)	260m	165m	90m	25m
2% superelevation	205m	120m	65m	25m
4% superelevation	150m	80m	45m	22m
6% superelevation	120m	-	-	-
Through Intersections	200m	120m	70m	40m

24. AND THAT SCHEDULE 5 OF BYLAW NO. 7900 CITY OF KELOWNA CONSTRUCTION SPECIFICATIONS, 1. CONSTRUCTION SPECIFICATIONS, be replaced in its entirety with a new schedule SCHEDULE 5 OF BYLAW NO. 7900 CITY OF KELOWNA CONSTRUCTION SPECIFICATIONS, 1. CONSTRUCTION SPECIFICATIONS as attached to and forming part of this bylaw as Appendix 'D';
25. AND THAT SCHEDULE 5 OF BYLAW NO. 7900 CITY OF KELOWNA CONSTRUCTION STANDARDS, 2 STANDARD DRAWINGS be amended by:
- a) adding in their appropriate numeric location, the following Standard Drawings as attached to and forming part of this bylaw as Appendix 'E':
 - i. Drainage Drywell Installation – SS-S52;
 - ii. Pipe Perforation and Bedding Detail for Ground Water Recharge – SS-S53; and
 - iii. IDF Curves – SS-S56; and
 - b) replacing the following Standard Drawings as attached to and forming part of this bylaw as Appendix 'E':
 - i. Sanitary Sewer Service connection SS-S7;
 - ii. Inspection Chamber for 100 to 200 Sanitary Sewer connection SS-S9.
26. This bylaw shall come into full force and effect as of the date of adoption.
27. This bylaw shall be cited as "Bylaw No. 10640, being Amendment No. 15 to Subdivision, Development and Servicing Bylaw No. 7900".

Read a first, second and third time by the Municipal Council this 12th day of March, 2012.

Adopted by 2/3 majority of the Municipal Council of the City of Kelowna this

Mayor

City Clerk

SCHEDULE 4
OF BYLAW 7900
CITY OF KELOWNA

DESIGN STANDARDS

1. WATER
2. SANITARY SEWER
3. DRAINAGE
4. HIGHWAY
5. ELECTRICAL, STREET LIGHTING AND
COMMUNICATION WIRING
6. **LANDSCAPE AND IRRIGATION**
6A – LANDSCAPE AND IRRIGATION WATER
CONSERVATION
6B – LANDSCAPE
6C - IRRIGATION
7. HILLSIDE DEVELOPMENT AND STREET STANDARDS

Appendix 'B':

TABLE 2
IDF CURVE VALUES for 1 HOUR STORM

Kelowna Airport						
	2 yr	5 yr	10 yr	25 yr	50 yr	100 yr
a=	8.8	12.2	14.4	17.2	19.3	21.3
b=	0.685	0.723	0.738	0.753	0.761	0.767

T (min)	STORM INTENSITY (mm/hr)					
	STORM					
	2	5	10	25	50	100
5						143
6						125
7					99	111
8				78	89	100
9			58	72	82	91
10	30	45	54	66	75	84
11	28	42	50	62	70	78
12	27	39	47	58	66	73
13	25	37	45	54	62	69
14	24	35	42	51	58	65
15	23	33	40	49	55	62
16	22	32	38	47	53	59
17	21	30	37	44	50	56
18	20	29	35	43	48	54
19	19	28	34	41	46	51
20	19	27	32	39	45	49
21	18	26	31	38	43	48
22	17	25	30	37	41	46
23	17	24	29	35	40	44
24	16	24	28	34	39	43
25	16	23	27	33	38	42
26	16	22	27	32	36	40
27	15	22	26	31	35	39
28	15	21	25	31	34	38
29	14	21	25	30	34	37
30	14	20	24	29	33	36
35	13	18	21	26	29	32
40	12	16	19	23	26	29
45	11	15	18	21	24	27
50	10	14	16	20	22	24
55	9	13	15	18	21	23
60	9	12	14	17	19	21

Based on 2004 Airport IDF values

Appendix 'C':

SCHEDULE 4 DRAINAGE, TABLE 3 - HYETOGRAPHS

Duration	Rainfall Depths						
	Duration	2 yr	5 yr	10 yr	25 yr	50 yr	100 yr
1.00	60	8.8	12.2	14.4	17.2	19.3	21.3
3.00	180	12.4	16.5	19.2	22.6	25.1	27.5
6.00	360	15.5	20.0	23.0	26.8	29.6	32.3
12.00	720	19.2	24.3	27.6	31.8	35.0	38.0
24.00	1440	23.9	29.4	33.1	37.7	41.3	44.7

Kelowna Airport						
	2 yr	5 yr	10 yr	25 yr	50 yr	100 yr
a=	8.8	12.2	14.4	17.2	19.3	21.3
b=	0.685	0.723	0.738	0.753	0.761	0.767

Time	t<= 6 hr Dist	t> 6 hr Dist	2 year					5 year					10 year				
			1 hr	3 hr	6 hr	12 hr	24 hr	1 hr	3 hr	6 hr	12 hr	24 hr	1 hr	3 hr	6 hr	12 hr	24 hr
0.00	0.00	0.00	0.0	0.0	0.0	0.0	0.0	0.0	0.0	0.0	0.0	0.0	0.0	0.0	0.0	0.0	0.0
0.08	0.08	0.08	0.7	1.0	1.2	1.5	1.9	1.0	1.3	1.6	1.9	2.4	1.2	1.5	1.8	2.2	2.6
0.17	0.10	0.09	0.9	1.2	1.5	1.7	2.2	1.2	1.7	2.0	2.2	2.6	1.4	1.9	2.3	2.5	3.0
0.25	0.19	0.10	1.7	2.4	2.9	1.9	2.4	2.3	3.1	3.8	2.4	2.9	2.7	3.6	4.4	2.8	3.3
0.33	0.20	0.10	1.8	2.5	3.1	1.9	2.4	2.4	3.3	4.0	2.4	2.9	2.9	3.8	4.6	2.8	3.3
0.42	0.09	0.10	0.8	1.1	1.4	1.9	2.4	1.1	1.5	1.8	2.4	2.9	1.3	1.7	2.1	2.8	3.3
0.50	0.08	0.11	0.7	1.0	1.2	2.1	2.6	1.0	1.3	1.6	2.7	3.2	1.2	1.5	1.8	3.0	3.6
0.58	0.07	0.11	0.6	0.9	1.1	2.1	2.6	0.9	1.2	1.4	2.7	3.2	1.0	1.3	1.6	3.0	3.6
0.67	0.06	0.11	0.5	0.7	0.9	2.1	2.6	0.7	1.0	1.2	2.7	3.2	0.9	1.2	1.4	3.0	3.6
0.75	0.05	0.08	0.4	0.6	0.8	1.5	1.9	0.6	0.8	1.0	1.9	2.4	0.7	1.0	1.2	2.2	2.6
0.83	0.04	0.07	0.4	0.5	0.6	1.3	1.7	0.5	0.7	0.8	1.7	2.1	0.6	0.8	0.9	1.9	2.3
0.92	0.03	0.03	0.3	0.4	0.5	0.6	0.7	0.4	0.5	0.6	0.7	0.9	0.4	0.6	0.7	0.8	1.0
1.00	0.01	0.02	0.1	0.1	0.2	0.4	0.5	0.1	0.2	0.2	0.5	0.6	0.1	0.2	0.2	0.6	0.7

Time	t<= 6 hr Dist	t> 6 hr Dist	25 year					50 year					100 year				
			1 hr	3 hr	6 hr	12 hr	24 hr	1 hr	3 hr	6 hr	12 hr	24 hr	1 hr	3 hr	6 hr	12 hr	24 hr
0.00	0.00	0.00	0.0	0.0	0.0	0.0	0.0	0.0	0.0	0.0	0.0	0.0	0.0	0.0	0.0	0.0	0.0
0.08	0.08	0.08	1.4	1.8	2.1	2.5	3.0	1.5	2.0	2.4	2.8	3.3	1.7	2.2	2.6	3.0	3.6
0.17	0.10	0.09	1.7	2.3	2.7	2.9	3.4	1.9	2.5	3.0	3.1	3.7	2.1	2.8	3.2	3.4	4.0
0.25	0.19	0.10	3.3	4.3	5.1	3.2	3.8	3.7	4.8	5.6	3.5	4.1	4.0	5.2	6.1	3.8	4.5
0.33	0.20	0.10	3.4	4.5	5.4	3.2	3.8	3.9	5.0	5.9	3.5	4.1	4.3	5.5	6.5	3.8	4.5
0.42	0.09	0.10	1.5	2.0	2.4	3.2	3.8	1.7	2.3	2.7	3.5	4.1	1.9	2.5	2.9	3.8	4.5
0.50	0.08	0.11	1.4	1.8	2.1	3.5	4.1	1.5	2.0	2.4	3.8	4.5	1.7	2.2	2.6	4.2	4.9
0.58	0.07	0.11	1.2	1.6	1.9	3.5	4.1	1.4	1.8	2.1	3.8	4.5	1.5	1.9	2.3	4.2	4.9
0.67	0.06	0.11	1.0	1.4	1.6	3.5	4.1	1.2	1.5	1.8	3.8	4.5	1.3	1.7	1.9	4.2	4.9
0.75	0.05	0.08	0.9	1.1	1.3	2.5	3.0	1.0	1.3	1.5	2.8	3.3	1.1	1.4	1.6	3.0	3.6
0.83	0.04	0.07	0.7	0.9	1.1	2.2	2.6	0.8	1.0	1.2	2.4	2.9	0.9	1.1	1.3	2.7	3.1
0.92	0.03	0.03	0.5	0.7	0.8	1.0	1.1	0.6	0.8	0.9	1.0	1.2	0.6	0.8	1.0	1.1	1.3
1.00	0.01	0.02	0.2	0.2	0.3	0.6	0.8	0.2	0.3	0.3	0.7	0.8	0.2	0.3	0.3	0.8	0.9

SCHEDULE 5
OF BYLAW 7900
CITY OF KELOWNA
CONSTRUCTION STANDARDS

**(SUPPLEMENTAL STANDARDS TO MMCD PLATINUM EDITION VOLUME II, PRINTED
2009)**

1. CONSTRUCTION SPECIFICATIONS
2. STANDARD DRAWINGS

BL8847 replaced Subsection 1 - Construction Specifications:

1. CONSTRUCTION SPECIFICATIONS

CITY OF KELOWNA SUPPLEMENTAL TO THE MASTER MUNICIPAL SPECIFICATIONS

This document is the City of Kelowna Supplement to the Master Municipal Specifications, 2009 Platinum Edition Volume II, and is to be applied in conjunction with the Master Municipal Specifications, which otherwise apply to all Works and Services constructed within the City of Kelowna.

The provisions of this Kelowna Supplement to the Master Municipal Specifications, supplement or supersede the provisions of the Master Municipal Specifications.

Where the provisions of the Kelowna Supplement are in conflict with the Master Municipal Specification the provisions of the Kelowna Supplement take precedence.

Section and article numbers in the Kelowna Supplement coincide with those of the Master Municipal Specifications.

BL10481 amended INDEX:

INDEX

SECTION

- 31 05 17S – Aggregates and Granular Materials
 - 31 23 01S – Excavating, Trenching and Backfilling
 - 31 24 13S – Roadway Excavation, Embankment and Compaction
 - 32 12 16S – Hot Mix Asphalt Concrete Pavement
 - 32 91 21S – Topsoil and Finish Grading
 - 32 91 22S – Structural Soils
 - 32 91 23S – Soil Cells
 - 32 93 01S – Planting of Trees, Shrubs & Ground Covers
 - 32 94 01S – Irrigation system
 - 33 11 01S – Waterworks
 - 33 30 01S – Sanitary Sewers
 - 33 34 01S – Sewage Force mains
 - 33 40 01S – Storm Sewers
 - 33 44 01S – Manholes and Catch Basins
- Appendix A Water Main Testing and Tie-in Procedure

2.1 Materials – General

Add: .3 The physical properties of the materials for granular sub-base and crushed granular base course shall meet the following specifications:

Physical Property	Test Designation	Granular Sub-base	Granular Base
MgSO ₄ Loss % Course Ag (Max) Fine Ag (Max)	ASTM C88	20 25	20 25
Sand Equivalent % (Min)	ASTM D2419	25	35
Plasticity Index % (Max)	ASTM D4318	6.0	6.0
Crushed Particles (one face) % (Min)	MoT I-11 (A)		60
California Bearing Ratio (Soaked) % (Min)	ASTM D1883	20	80

2.7 Granular Pipe Bedding and Surround Material

Replace: .2 Pit run sand as specified in Section 31 05 17 (2.4) may also be used unless otherwise specified by the Contract Administrator.

Add: .3 Other permissible materials: Only where shown on Contract Drawings or directed by the Contract Administrator shall drain rock or approved native materials be used for bedding and pipe surround.

2.8 Select Granular Sub-base

Replace: .1 To be well graded granular material, substantially free from lumps and organic matter, screened if required to conform to the following gradations:

Sieve Designation	Percent Passing
150 mm	100
100 mm	85 - 100
50 mm	65 - 100
19 mm	40 - 100
4.75 mm	20 - 70
0.150 mm	0 - 20
0.075 mm	0 - 8

Add: .2 Maximum aggregate particle size to be no more than 50% of total thickness of sub-base layer.

2.10 Granular Base

Replace: .1 To be 25 mm crushed gravel conforming to the following gradations:

Sieve Designation	Percent Passing
25 mm	100
19 mm	80 - 100
9.5 mm	60 - 90
4.75mm	35 - 70
2.36 mm	25 - 50
1.18 mm	15 - 35
0.300 mm	5 - 20
0.075 mm	2 - 8

2.11 Recycled Aggregate Material

Replace: .1 Aggregates containing recycled material may be utilized if approved by the Contract Administrator. In addition to meeting all other conditions of this specification, recycled material should not reduce the quality of construction achievable with quarried materials. Recycled material should consist only of crushed Portland cement concrete and asphalt pavement. Other construction and demolition materials such as bricks, plaster, etc. are not acceptable.

Add: .2 Material retained on the 4.75 mm sieve to be not more than 20% recycled material. Minimum size of processed recycled material is to be retained on the 4.75 mm sieve.

Add: .3 Recycled material and granular sub-base material is to be mechanically blended to produce a homogeneous mixture prior to delivery to site. Blending on site will not be permitted.

Add: .4 Acceptable recycled material to be used in sub-base material only.

3.6 Surface Restoration

.7 Permanent pavement restoration

- Replace: .5 Restore pavement as detailed on City of Kelowna Supplemental Standard Detail Drawing SS-G5.
- Add: .1 All asphalt shall be saw cut 500 mm wider and longer than the surface dimensions of the actual trench excavation. This saw cut must extend cleanly through the existing asphalt to the base material prior to asphalt removal.
- Add: .2 If the thickness of the existing asphalt is greater than 75 mm, grind it to a depth of 40 mm and a width of 200 mm along the saw cut edge. This can be done just prior to the final asphalt restoration.
- Add: .3 Where the edge of the saw cut or milled asphalt, whichever is wider, extends into the travel lane, it should be extended to the mid point of that lane. Where the edge extends past the mid point of the travel lane, it should be extended to the far edge of that travel lane.
- Add: .4 Where the edge of the saw cut or milled asphalt, whichever is wider, is less than 1.5 m from the lip of gutter or edge of paved shoulder, it should be extended to the lip of gutter or edge of paved shoulder.
- Add: .5 When an area of existing asphalt between two transverse trenches is less than one third (1/3) of the total area of the proposed paving of the two trenches plus the area between them (based on the shortest trench), the existing asphalt shall be removed and the area paved in conjunction with the paving of the two trenches.
- Add: .6 Regardless of 7.5.5, if the longitudinal distance between two trenches is less than three (3) meters it shall be removed and the area paved in conjunction with the paving of the two trenches.
- Add: .7 Longitudinal trenches must be paved with a paving machine.
- Add: .8 Hot-mix paving shall meet the thickness of the existing pavement or that shown on the design drawings, whichever is greater. If the thickness of the hot-mix paving is 75 mm or less, it shall be placed in one lift. If the thickness of the hot-mix paving is greater than 75 mm it shall be placed in two lifts as shown on Drawing SS-G5.
- Add: .9 Vertical faces and the surface of the bottom lift of asphalt must be painted with bituminous material prior to hot mix paving.

BL8847 added Section S02224:

3.3 Inspection of Native Surface

Add .2 Top 150 mm of Native Surface to be scarified, moisture conditioned to optimum moisture content and compacted to a minimum of 95% of Modified Proctor density in compliance with ASTM D1557, before placing of embankment or sub-base material.

2.0 PRODUCTS

2.1 Materials

- Replace: .1 Asphalt cement: to CGSB-16.3-M90, Grade 80-100, Class A.
- Replace: .3 .2 Gradations to be within limits specified when tested to ASTM C136 and ASTM C117.

**Table 2.1.3.2
Hot Mix Asphalt Aggregate Gradation Specification**

Sieve Designation	Percent Passing	
	Lower Course	Surface Course
25 mm	100	-
19 mm	80-100	100
12.5 mm	-	84-95
9.5 mm	50-84	73-90
4.75 mm	25-55	50-75
2.36 mm	20-45	35-57
1.18 mm	15-35	25-45
0.600 mm	-	18-34
0.300 mm	5-20	10-26
0.150 mm	-	6-17
0.075 mm	3-7	3-7

- Replace: .3 .6 Sand Equivalent: to ASTM D2419. Min: 50 (New Arterial), Min: 40 (All other street classifications).
- Replace: .3 .10 Lightweight particles: to ASTM C123. Maximum % by mass less than 1.95 relative density:
 .1 Surface course: 1.0
 .2 Lower course: 1.5"

City of Kelowna Supplemental Master Municipal Specifications	Hot Mix Asphalt Concrete Paving	Section 32 12 16S Page 2 of 8
--	---------------------------------------	----------------------------------

- | | | | |
|----------|----|-----|---|
| Replace: | .3 | .11 | Flat and elongated particles: (with length to thickness ratio greater than 5): Maximum % by mass: |
| | | | .1 Coarse aggregate, surface course: 10 |
| | | | .2 Coarse aggregate, lower course: 10" |
| Replace: | .3 | .12 | Crushed Particles (fraction retained on 4.75 mm sieve), 2 faces, % minimum: |
| | | | .1 <u>New</u> arterial streets: 85 |
| | | | .2 All other street classifications: 70" |

2.2 Mix Design

- | | | |
|----------|----|--|
| Replace: | .1 | The Contractor, at their cost, must retain an independent testing consultant to perform trial mix designs and to submit the job mix formula. The trial mix design must be performed in accordance with ASTM D1559 (75 blows per face) and must include five (5) separate trial values of asphalt content. Contractor must pay for trial mix designs and submissions. |
| Replace | .2 | Mixes for construction of asphalt base course may contain up to 20% of RAP, provided that the properties of RAP material are considered in the trail mix design. Submissions for RAP mixes must contain all data relevant to RAP utilized in the mix design. |
| Replace: | .3 | Design of Mix: Include the following data with the trial mix design submission: |
| | | .1 Aggregate bulk specific gravity and water absorption. |
| | | .2 Sand equivalent values. |
| | | .3 Asphalt cement properties including mixing and compaction temperatures, based on temperature viscosity properties of asphalt cement. |
| | | .4 Aggregate gradations and blending proportions. |
| | | .5 Maximum theoretical density of trial mixes. |
| | | .6 Asphalt absorption values. |
| | | .7 Mix physical requirements to meet Table 2.2.3 below. |
| | | .8 Do not change job-mix without prior approval to Contract Administrator. Should change in material source be proposed, new job-mix formula to be submitted to Contract Administrator for review and approval. |

**Table 2.2.3
Specified Physical Requirements of Hot Mix Asphalt**

Property	Mix Type	
	Lower Course ⁽¹⁾	Surface Course
Stability @ 60°C, kN (min)	8.0	9.0
Flow Index, 0.25 mm units	8-14	8-14
Voids in Mineral Aggregate % (min)	12.0	14.0
Air Voids, % ⁽²⁾	3-6	3-5
Index of Retained Stability after Immersion in Water for 24 hrs @ 60°C, % (min)	75	85

- Notes: (1) If lower course mix is used in staged construction, i.e. exposed for at least one winter, specified properties for surface course mix must apply.
(2) Percent air voids in compacted trial mixes must be determined in accordance with ASTM D3203, with asphalt cement absorbed into the aggregate compensated for in the calculation.

3.0 EXECUTION

3.1 Plant and Mixing Requirements

- .1 Batch and continuous mixing plants:
- Replace: .3 Before mixing, dry aggregates to a moisture content not greater than 1% by mass or to a lesser moisture content if required to meet mix design requirements.
- Replace: .9 Where RAP is to be incorporated into the mix:
.3 RAP must not be fed through the aggregate dryer system.
- Add: .11 Mixing time:
.3 Mixing period and temperature to produce a uniform mixture in which particulates are thoroughly coated, and moisture content of material as it leaves mixer to be less than 0.2%.
- .4 Mixing Tolerances:
- Replace: .1 Permissible variation in aggregate gradation from job mix (percent of total mass):
- | | | |
|----|--------------------|--------|
| .1 | 4.75 mm and larger | ± 4.5 |
| .2 | 2.36 and 1.18 mm | ± 4.0 |
| .3 | 0.600 mm | ± 3.5 |
| .4 | 0.300 mm | ± 2.5 |
| .5 | 0.150 mm | ± 1.5 |
| .6 | 0.075 mm | ± 1.0" |

3.2 Equipment

- Add to .1 Pavers: .1 Pavers must be capable of placing a standard mat width not less than 3 m and must be capable of paving wider widths in 150 mm and 300 mm increments by means of equipment supplied by the manufacturer of the equipment. The screed must include a tamping bar or strike-off device.
- .2 Control of the screed must be by automatic sensing devices. Longitudinal control must be by a sensor that follows a string-line, ski or other reference. The grade sensor must be movable and mounts provided so that grade control can be established on either side of the paver. A slope control sensor must be provided to maintain the proper transverse slope of the screed.

3.6 Compaction

- .2 General:
- Replace: .1 Provide sufficient compaction equipment to ensure that the compaction rate meets or exceeds the placement rate and to ensure that specified density is achieved before the temperature of the mat falls below 100°C.

3.7 Joints

- .1 General:
- Add: .4 When placing final pavement layer against concrete curbing, compacted pavement must meet the gutter at the same elevation or a maximum of 10 mm above and along the entire lip of the gutter.

Add the following Sub-Sections:

4.0 COMPLIANCE WITH SPECIFICATIONS AND PAYMENT ADJUSTMENT FOR NON-COMPLIANCE

4.1 Hot Mix Asphalt Concrete

- .1 A Marshall analysis will performed from a sample obtained at the paving site on a frequency of one analysis per day, with at least one analysis required per project or 700 tonnes of asphalt.
- .2 When analysis identifies non-conformance with specified properties, the Contractor must immediately initiate remedial measures, and submit, at its expense, evidence that compliance exists with the approved mix design. Failure to do so will result in suspension of plant mixing operations.

4.2 Aggregate Gradation

- .1 When the aggregate fails to comply with tolerances set forth in Section 3.1.4.1 of this specification, the Contract Administrator will initiate the following action:
 - .1 When two (2) consecutive gradation analyses identify non-compliance with the specified tolerances, the contractor must be served notice and a third test will be initiated.
 - .2 If continued non-compliance is indicated from the third test, the Contractor must suspend production. It must not commence construction again until it has demonstrated that corrective action has been taken and that the aggregate gradation is within the specified tolerance limits.

4.3 Asphalt Cement

- .1 Payment adjustment for non-compliance with the tolerance specified:

Asphalt Content Deviation from Design %	Payment Adjustment Factor
0.30 OR LESS	0.00
0.31 TO 0.40	0.20
0.41 TO 0.50	0.75
0.50 OR GREATER	Remove and replace

- .2 Adjustment for asphalt cement content non-compliance to the amount payable for Hot Mix Asphalt Paving equals the unit bid price times the payment adjustment factor times the quantity to which the factor is to be applied, i.e.:

$$A_c = P (F_c) (Q_n)$$

where:

A_c = Adjustment for asphalt cement content non-compliance

P = Unit bid price

F_c = Payment Adjustment Factor for Asphalt Cement Content non-compliance

Q_n = Asphalt measured for payment which was produced during the production period to which a test applies

4.4 Pavement Thickness

- .1 Pavement of any type found to be deficient in thickness by more than 10 mm must be removed and replaced by pavement, of specified thickness, at the contractor's expense.
- .2 Pavement of any type found to be deficient by less than 10 percent of its specified compacted thickness will not be subject to payment adjustment for thickness non-compliance.
- .3 Pavement of any type found to be deficient in thickness by more than 10 percent of its specified thickness but not more than 10 mm shall give rise to an adjustment in the amount to be paid to the Contractor. The adjustment shall be subtracted from the amount otherwise payable to the Contractor, and the amount of the adjustment will be paid to the City. The adjustment shall be calculated as follows:

$$A_t = \frac{T_d}{T_s} \times P \times Q_t$$

where:

A_t = Adjustment for thickness deficiency

T_d = Deficiency in thickness measured in mm and being greater than 10% of specified thickness but not greater than 10 mm.

T_s = Specified thickness in mm.

Q_t = Asphalt measured for payment lying within a unit of work area defined in 5.2.2, where the thickness deficiency has been identified.

P = Unit Bid Price.

NOTE: No allowance will be made for the tolerance provided for in Section 4.4.2.

- .4 The adjusted price will be applied to all asphalt measured for payment which lies within a unit of work area defined in 5.2.2 where the thickness deficiency had been identified, or to such lesser area as may be defined in accordance with the provisions of 5.2.2.

4.5 Density

- .1 The minimum specified density for acceptance, without payment adjustment, must be 97% of the 75 blow Marshall density as most recently determined by the appointed testing agency.
- .2 Payment adjustment for density non-compliance will be as follows:

City of Kelowna Supplemental Master Municipal Specifications	Hot Mix Asphalt Concrete Paving	Section 32 12 16S Page 7 of 8
--	---------------------------------------	----------------------------------

DENSITY (% OF 75 BLOW MARSHALL)	PAYMENT ADJUSTMENT FACTOR
97 and greater	0.0
95.0 to 96.9	As per Density Payment Adjustment Factor Chart (see Standard Drawing SS-R24)
Less than 95.0	No Payment (subject to removal and replacement after review by the Engineer)

Adjustment for density specification non-compliance shall be determined as follows:

$$A_D = P (F_D) (Q_{ND})$$

where:

A_D = Adjustment for density non-compliance

P = Unit Bid Price for Hot Mix Asphalt Cement paving

F_D = Payment Adjustment Factor for density non-compliance

Q_{ND} = Asphalt measured for payment within a unit of test area as defined in 5.3.

4.6 Adjusted Payments

- .1 The total adjustment arising from pavement deficiencies identified in the foregoing shall be determined as follows:

$$A_r = A_c + A_t + A_D$$

where:

A_r = Total Adjustment

A_c = Adjustment for asphalt cement content non-compliance

A_t = Adjustment for thickness deficiency

A_D = Adjustment for density non-compliance

The total adjustment (A_r) shall be paid to the City.

5.0 TESTING FREQUENCY AND PROCEDURES

5.1 Aggregate Gradation and Asphalt Cement Content

- .1 One test per production period as defined in Section 4.1.1. Asphalt content shall be determined in accordance with ASTM D2172 or D6307. Gradation analysis of extracted aggregate shall be performed in accordance with ASTM C136 and C117.

5.2 Thickness

- .1 The actual pavement thickness, for each unit of work area, will be determined on the basis of the average thickness of three (3) cores. The cores shall be spaced at intervals of 150 m of paved lane width or less. If the deficiency of any individual core exceeds 10 mm, three (3) additional cores may be extracted in proximity to the location of the core of excessive deficiency, to identify the extremities of the pavement area to be removed and replaced. The contractor will initiate and pay for such additional coring.
- .2 A unit of work area is defined as 1,500 m² or fraction thereof, representing pavement placed in an individual placement day.
- .3 Sampling and testing for thickness determination shall be in accordance with ASTM D3549.

5.3 Density

- .1 Density of compacted pavement shall be determined on the basis of tests on core samples taken at a maximum interval of 150 m of paved lane width. A test area shall be that area lying between longitudinal joints and between transverse lines located midway between test cores or between such transverse lines and the beginning or end of placement.
- .2 With prior approval of the City Engineer, the in situ density of a compacted layer of pavement may also be determined by nuclear methods in accordance with ASTM D 2950. Spacing of tests shall be as stated above, and tests shall be taken in the vicinity of the core samples extracted for testing of the thickness of the pavement layer. In a situation where the in situ density of the lift does not meet specification, according to D 2950, then the density of the extracted cores shall be determined and will take precedent over the in situ density. Where the specified compaction has not been met, as confirmed by the direct measurement of the core, then an additional three cores shall be taken in the immediate area and the average of the three cores shall be used.

- 1.3 Source Control**
- Quality**
- .1 Replace clause with:
- “Within 5 days of receiving Notice to Proceed advise Contract Administrator of location of each proposed source of supply of growing medium and amendment (e.g. peat moss, manure, compost). Make proposed sources of supply available to Contract Administrator for viewing and sampling.
- .3 Add clause:
- “Do not manufacture, supply or place growing medium and amendments that will not or do not meet the physical and chemical properties described in this Section without prior written approval of Contract Administrator”.
- .4 Add clause:
- “After all growing medium is placed allow minimum 20 days for Contract Administrator to have placed growing medium sampled and analysed before determining if growing medium is compliant with this Section and if a full or partial payment for supply and placement of growing medium is owed to Contractor.”
- 1.4 Measurement and Payment**
- and**
- .1 Replace clause with:
- “Payment for growing medium, imported topsoil and re-use of native topsoil will be made separately for each type of growing medium and topsoil specified, and includes supply of materials, screening, mixing, handling, subgrade scarification, placement to specified thickness, finish grading and application of fertilizers, organic material and other amendments. Payment for growing medium, imported topsoil and re-use of native topsoil will be by actual area provided to specified thickness.”
- .2 Replace clause with:
- “Payment for topsoil and finish grading will be withheld pending Contract Administrator’s review of the soil analysis results.”
- .3 Replace clause with:
- “Payment for excavation, screening and stockpiling of native topsoil will be made under Section 31.22.01 – Site Grading.”
- .4 Add clause:
- “If analysis of placed growing medium indicates that the physical or chemical properties of the material varies from the limits and ranges specified in this Section, the Contract Administrator may do one or a combination of the following:
- .1 Require removal and replacement of growing medium that does not meet the limits and ranges specified in this Section.
- .2 Require the application and incorporation of soil amendments to enable the soil to meet the physical and

chemical requirements specified in this Section.

- .3 Accept the work at a reduced price determined by G.C. 9 Valuation of Changes and Extra Work.
- .4 No additional payment will be made for removal, replacement, repair or adjustment of growing medium or other work, including removal and replacement of plant material and irrigation components, that is or may be impacted by removal and replacement of unsuitable growing medium.

1.5 Inspection Testing

and .2 Add clause:

“Submit 1.0kg sample of each proposed material and amendment to Contract Administrator and soil testing laboratory.”

.3 Add clause:

“Independent soil testing laboratory to be approved by Contract Administrator.”

.4 Add clause:

“Have testing laboratory analyse samples for chemical, physical and biological properties specified in this Section, to include pH, lime requirements, soluble salts or electrical conductivity (E.C.), % Sands + % Fines (Silt and Clay) + % Organic Matter = 100%, % Total Nitrogen, and available levels of phosphorous, potassium, calcium and magnesium.”

.5 Add clause:

“Have testing laboratory advise on suitability of material for intended use and make recommendations for manufacture and amendment of growing medium to meet requirements of Contract Documents.”

2.7 Manure

.6 Add clause:

“Use of manure to be approved in writing by Contract Administrator prior to mixing or placement.”

2.10 Table 2

Replace Table 2 with:

“Table 2: Properties of Growing Medium for Different Applications				
<u>Tree Pits & Low Traffic Lawn Areas</u>	<u>High Traffic Lawn Areas</u>	<u>Planting Beds & Planters</u>	<u>Naturalized Grass</u>	<u>Naturalized Beds</u>
<u>Particle Size (% of dry weight mineral fraction per Canadian System of Soil Classification)</u>				

Gravel >2mm	0-5	0-5	0-5	0-10	0-10
Sand 0.05mm-2mm	50-70	80-90	50-70	30-70	30-70
Silt 0.002mm-0.05mm . .	10-25	5-15	10-25	15-50	15-50
Clay <0.002mm	0-20	0-5	0-20	15-30	15-30
Silt + Clay	25 max	15 max	25 max	60 max	60 max
Acidity (pH)	6.0-7.0	6.0-7.0	5.5-7.0	6.0-7.0	6.0-7.0
Organic Content (% of dry weight)	3-5	3-5	15-20	5-10	10-15
Drainage	Percolation shall be such that no standing water is visible 60 minutes after at least 10 minutes of moderate to heavy rain or irrigation."				

2.11 Compost

.1 Add clause:

“Compost to be uniform blend of natural source-separated organic materials, composted such that it is brown-black in colour and has carbon to nitrogen ratio of 25 to 1 or lower and pH 6 to 7. Compost to be substantially free from subsoil, pests, roots, wood, construction debris, undesirable grasses or weeds, and seeds or parts thereof. Compost to be substantially free from toxic materials, crabgrass, couchgrass, equisetum, other weeds, and seeds or parts thereof.”

.1 Add clause:

“Use of compost to be approved in writing by Contract Administrator prior to mixing or placement.”

3.4 Placing Medium

Growing

.5 Replace clause with:

“Place growing medium to minimum depth after settlement specified on Contract Drawings. Where no depth is specified on Contract Drawings place growing medium to minimum depth after settlement specified in Table 3.

.6 Add clause:

“Determination of minimum growing medium depth after placement will be made at the time of inspection for Substantial Performance.”

3.10 Drainage Control

.1 Add clause:

“Provide proper water management and drainage of site during construction. Include silt traps, erosion control measures, temporary water collection ditches, as well as maintenance during construction period.”

- 1.0 GENERAL** Section 32 91 22S refers to those portions of the work that are unique to the use of structural soils for the planting of trees and landscaping in pedestrian and vehicular areas. This section must be referenced to and interpreted simultaneously with all other sections pertinent to the works described herein.
- 1.1 Related Work**
- | | | |
|----|---|-------------------------|
| .1 | Concrete Walks, Curbs and Gutters | <u>Section 03 30 20</u> |
| .2 | Cast-in-Place Concrete | <u>Section 03 30 53</u> |
| .3 | Aggregates and Granular Materials | <u>Section 31 05 17</u> |
| .4 | Excavation, Trenching and Backfilling | <u>Section 31 23 01</u> |
| .5 | Roadway Excavation, Embankment and Compaction | <u>Section 31 24 13</u> |
| .6 | Geosynthetics | <u>Section 31 32 19</u> |
| .7 | Granular Base | <u>Section 32 11 23</u> |
| .8 | Topsoil and Finish Grading | <u>Section 32 91 21</u> |
| .9 | Planting of Trees, Shrubs and Ground Covers | <u>Section 32 93 01</u> |
- 1.2 Mix Design** Ratio of materials for structural soil mix design to be approximately as follows:
- .1 Crushed stone: 100 unit dry weight
 - .2 Growing medium: 20 unit dry weight
 - .3 Soil stabilizer: 0.03 units dry weight
- Actual mix design subject to material characteristics, site conditions and Contract Administrator's approval of materials and mix sample.
- Prepare up to three different structural soil mix design ratios and submit to Contract Administrator for review and comment.
- Based on direction of Contract Administrator prepare up to three different sample structural soil mixes, minimum 0.5m³ volume each, and deliver to site for review and approval of one sample by Contract Administrator.
- 1.3 Delivery, Storage and Handling** .1 Minimize handling and movement of structural soil to prevent

segregation of growing medium from crushed stone.

- .2 Do not handle, deliver or place structural soil in frozen, wet or muddy conditions.
- .3 Deliver materials to site at or near optimum compaction moisture content.
- .4 Place structural soil as shown on Contract drawings within 24 hours of delivery to site. Do not store material on site.
- .5 Protect excavation from freezing conditions, accumulation of water and contamination until placement of structural soil. Maintain protection of excavation and placed structural soil until installation of hard surfaced roadway or pedestrian surface above.
- .6 Structural soils that are excessively wet, segregated or contaminated will be rejected. Remove rejected structural soil from site and replace with approved material at Contractor's expense.

1.4 Site Conditions

- .1 Inspect all areas to receive structural soil prior to placement.
- .2 Before proceeding with Work of this Section check and verify dimensions, quantities, grade elevations, drainage, compaction and contamination.
- .3 Report defects in dimensions, quantities, grade elevations, drainage, compaction and contamination to Contract Administrator immediately and make good to satisfaction of Contract Administrator prior to placement of structural soil.

1.5 Scheduling

- .1 Schedule placement of structural soil after all affecting walls, curbs, footings and utility work in the area have been installed.
- .2 Coordinate schedule with scheduling of other trades on site.

1.6 Measurement and Payment

- .1 Payment for structural soil will be made separately for each type of structural soil specified, and includes crushed stone and growing medium material supply, mixing, amendments, site preparation, placement, compaction, geotextiles, protection of work and incidentals. Payment for structural soil will be by actual volume placed.
- .2 Payment for excavation, backfilling and embankment of structural soil work area will be made under Section 31 23 01 - Excavating, Trenching and Backfilling or Section 31 24 13 - Roadway Excavation, Embankment and Compactions, as provided in the Schedule of Quantities and Unit Prices.

- .3 Payment for placement and compaction of subbase and base associated with structural soil will be made under Section 32.11.16.1 - Granular Subbase and 32.11.23 - Granular Base, as provided in the Schedule of Quantities and Unit Prices.
- .4 Payment for pedestrian or vehicle surfaces above structural soil will be made under separate sections as appropriate
- .5 Payment for tree planting, associated non-structural growing medium, root barrier and tree grates will be made under separate sections as appropriate.

1.7 Inspection Testing

and

- .1 Refer to General Conditions, Clause 4.12, Inspections.
- .2 Refer to Section 32.91.21 - Topsoil and Finish Grading - 1.3 and 1.5.
- .3 Submit 10.0kg sample of each proposed crushed stone material to Contract Administrator and testing laboratory.

2.0 PRODUCTS**2.1 Crushed Stone**

- .1 Crushed stone to be crushed granite greater than 19mm and less than 50mm in size and conforming to the following graduations:

ASTM Sieve Designation	Percent Passing
40mm	90-100
25mm	20-55
10mm	10

- .2 Ratio of aggregate dimensions not to exceed 2.5:1 for any two dimensions chosen.
- .3 Minimum 90 per cent with one fractured face and minimum 75 percent with two or more fractured faces.

2.2 Growing Medium

- .1 Growing medium to be as specified in Section 32.91.21 for tree pit or planting bed application as shown on Contract Drawings.

2.3 Soil Stabilizer

- .1 Soil stabilizer to be non-toxic organic binder or hydrogel. Acceptable soil stabilizers include:
 - .1 Natural Solution by Sport Turf Inc, 604-850-7857
 - .2 Gelscape by Amereq Corporation, 800-832-8788

2.4 Filter Fabric

- .1 Non woven filter fabric to conform to the following designations:

- .1 Grad Tensile Strength, per ASTM D-4632: 400kN
- .2 Tensile Elongation, per ASTM D-4632: 50%
- .3 Mullen Burst, per ASTM D-3786: 1270kPa
- .4 Flow rate, per ASTM D-4491: 6300 l/min/m²

2.5 Root Barrier

- .1 Root barrier to be per Section 32.93.01 - Planting of Trees, Shrubs and Ground Covers .

3.0 EXECUTION**3.1 Manufacturing and Mixing**

- .1 Use approved materials only.
- .2 Manufacture and mix structural soil off-site using appropriate soil measuring, mixing and shredding equipment of sufficient capacity and capability to assure proper quality control and consistent mix ratios. Mixing of structural soil at site not permitted.
- .3 Mix materials in ratios per approved mix design and sample. Supplier to provide mix design to City of Kelowna. Subject to supplier mix design, the mix may be approximately 100 units dry stone, 20 units growing medium, and 0.03 units soil stabilizer.
- .4 Do not manufacture structural under freezing conditions.
- .5 Prepare first batch of structural soil with Contract Administrator present at mixing site to confirm appropriate moisture content and mixing procedure for manufacture of structural soil.
- .6 Growing medium should shred and break down without clumping into a fine crumbly texture.
- .7 Add moisture gradually and evenly during the blending and turning operation as required to achieve the required moisture content. Soils shall not be overly wet or dry. Maintain adequate moisture content during the mixing process. Measure and monitor amount of soil moisture regularly during mixing process.
- .8 Mix sufficient material in advance of the time needed at the job site to allow adequate time for final quality control testing as required by the progress of the work.
- .9 Protect storage piles from rain, erosion and contamination.

-
- 3.2 Site Preparation**
- .1 Excavate sub-grade to specified depths, slopes and widths as shown on Drawings. Maintain required angles of repose of adjacent materials and protect adjacent structures from damage and structural compromise. Do not over excavate compacted sub-grades of adjacent pavement or structures.
 - .2 Confirm that the sub-grade is at specified elevations and compaction.
 - .3 Clear excavation of all construction debris, trash, rubble, fuels, oils, concrete and foreign material. Replace over-excavated subgrade with approved material and compact to specified grade and compaction.
 - .4 During placement protect adjacent walls, walks, utilities and structures from damage or staining by structural soil. Make good any damage or staining to adjacent wall, walk, utility or structure at Contractor's expense.
- 3.3 Structural Soil**
- .1 Place structural soil in 150mm thick lift and compact lift to 95% Modified Proctor Density and obtain approval of compaction before placement of next lift. Continue until structural soil is at its finished grade.
 - .2 Call for inspection of placed structural soil by Contract Administrator.
 - .3 Protect structural soil from freezing, excessive rain or moisture, erosion, silts, clays, cement, concrete, contaminants and pollutants.
- 3.4 Filter Fabric**
- .1 Install filter fabric on structural soil per Contract Drawings immediately after inspection and approval by Contract Administrator.
 - .2 Provide 600mm overlap at all joints.
- 3.5 Granular Base**
- .1 Supply and install aggregate base course above structural soil system as shown on Contract Drawings and as specified in Section 32.11.23 - Granular Base.
 - .2 Install granular base course on filter fabric immediately after installation of filter fabric.
- 3.6 Protection of Work**
- .1 Protect structural soil and filter fabric from vehicles, equipment, other materials and excessive moisture.
 - .2 Use temporary fencing or hoarding to keep vehicles and equipment away off structural soil area until final surface materials are placed.

3.7 Clean Up

- .1 Dispose of surplus materials and all construction debris off site.

-
- 1.0 GENERAL** Section 32 91 23S refers to those portions of the work that are unique to the use of soil cells for the planting of trees and landscaping in pedestrian and vehicular areas. This section must be referenced to and interpreted simultaneously with all other sections pertinent to the works described herein.
- 1.1 Related Work**
- .10 Concrete Walks, Curbs and Gutters Section 03 30 20
 - .11 Cast-in-Place Concrete Section 03 30 53
 - .12 Aggregates and Granular Materials Section 31 05 17
 - .13 Excavation, Trenching and Backfilling Section 31 23 01
 - .14 Roadway Excavation, Embankment and Compaction Section 31 24 13
 - .15 Geosynthetics Section 31 32 19
 - .16 Granular Base Section 32 11 23
 - .17 Irrigation System Section 32 94 01S
 - .18 Topsoil and Finish Grading Section 32 91 21
 - .19 Planting of Trees, Shrubs and Ground Covers Section 32 93 01
- 1.2 Mock Up**
- .1 Prior to the installation of soil cell system, construct a mock up of complete installation. Construction of mock up to be in presence of Contract Administrator.
 - .2 Mock up to be a minimum 10m² in area and to consist of complete soil cell system, including soil cell frames, geogrid, growing medium, soil cell deck and geotextile, all installed in excavation on prepared and approved granular base, geotextile and subgrade.
 - .3 Mock up may, upon approval of Contract Administrator, remain as part of the installed work at end of project if it remains in good condition and meets requirements of Contract Documents. Otherwise mock-up to be removed at Contractor's expense.
- 1.3 Site Conditions**
- .4 Inspect all areas to receive soil cells prior to placement.
 - .5 Before proceeding with work check and verify dimensions, quantities, grade elevations, drainage, compaction and contamination.

-
- .6 Report defects in dimensions, quantities, grade elevations, drainage, compaction and contamination to Contract Administrator immediately and make good to satisfaction of Contract Administrator prior to construction of soil cell system.
- 1.4 Delivery, Storage and Handling**
- .7 Deliver packaged materials in original, unopened containers showing weight, certified analysis and name and address of manufacturer.
- .8 Do not handle, deliver or place bulk materials in frozen, wet or muddy conditions.
- .9 Deliver materials to site at or near optimum compaction moisture content.
- .10 Protect excavation from freezing conditions, accumulation of water and contamination until placement of soil cells, growing medium, geotextile and root barrier. Maintain protection of excavation and placed material until installation of hard surfaced roadway or pedestrian surface above.
- .11 Growing medium, granular base and backfill that is excessively wet, segregated or contaminated will be rejected. Remove rejected material from site and replace with approved material at Contractor's expense.
- 1.5 Layout and Elevation Control**
- .1 Provide layout and elevation control during installation of soil cells. Utilize grade stakes, benchmarks, surveying equipment and other means and methods to ensure that layout and elevations conform to layout and elevations shown on Contract Drawings
- 1.6 Scheduling**
- .3 Schedule installation of soil cells after all affecting walls, curbs, footings and utility work in the area have been installed.
- .4 Coordinate schedule with scheduling of other trades on site.
- 1.7 Measurement and Payment**
1. Payment for soil cells will be made separately for each vertical column of soil cell assembly, and includes all soil cell components, growing medium, site preparation, placement, geogrid and geotextile, protection of work and incidentals. Payment will be made separately for assemblies comprised of one, two or three layers of soil cell frames.
2. Payment for excavation, backfilling and embankment of soil cells will be made under Section 31.23.01 - Excavating, Trenching and Backfilling or Section 31.24.13 - Roadway Excavation, Embankment and Compaction, as provided in

the Schedule of Quantities and Unit Prices.

3. Payment for placement and compaction of granular base will be made under Section 32.11.23 - Granular Base, as provided in the Schedule of Quantities and Unit Prices.
4. Payment for pedestrian or vehicle surfaces above soil cells will be made under separate sections as appropriate
5. Payment for tree planting, associated non-soil cell growing medium, root barrier, tree grates and concrete surrounds will be made under separate sections as appropriate.

1.8 Inspection Testing

and

- .1 Refer to General Conditions, Clause 4.12, Inspections and Testing.
- .2 Refer to Section 32.91.21 - Topsoil and Finish Grading - 1.3 and 1.5.

2.0 PRODUCTS

2.1 Soil Cell

- .1 Soil cell to be fiberglass-reinforced polypropylene structure, or other materials, designed to support sidewalk loads, designed to be filled with growing medium for the purpose of growing tree roots, and for rainwater filtration, detention and retention.
- .2 Acceptable soil cell systems include the following:
 - .1 Silva Cell by DeepRoot Partners, including:
 - .1 Silva Cell frame: 400x600x1200mm
 - .2 Silva Cell deck: 50x600x1200mm, including manufactured installed galvanized steel tubes
 - .3 Silva Cell modified: 400x600x150mm modified Silva Cell frame designed to stiffen and align frames as growing medium and backfill is placed
 - .4 Silva Cell deck screws: manufacturer supplied stainless steel screws to attach decks to frames
 - .2 Approved Equal

2.2 Anchor Spike

- .1 Galvanized steel spike with spiral twist, 8mm diameter and 250mm length.

2.3 Drainage Pipe

- .1 Drainage pipe to be perforated drain pipe per Section 33.40.01 - Storm Sewers - 2.7, as specified on Drawings.
- .2 Fittings to be compatible with specified pipe and by same manufacturer.

- .3 PVC pipe solvent and primer combinations shall be as recommended by manufacturer and suitable for use with specified materials and application.
- 2.4 Inspection Assmebly** **Riser**
- .1 Inspection riser to be 100mm diameter Schedule 40 non-perforated PVC pipe per Section 32.94.01S– Irrigation System. Cut four (4) 3mm wide slots in bottom of pipe that extend to soil cell deck to allow water access for inspection.
- .2 Fittings and caps to be compatible with specified pipe and by same manufacturer. Cap to be solid threaded cleanout or removable inlet grate designed to fit inspection riser and be compatible with pedestrian traffic and operational practice.
- 2.5 Geogrid**
- .1 Geogrid to be high molecular weight high tenacity polyester multifilament yarns woven in tension and polymer-coated, with the following ASTM D 6637 mechanical properties:
- .1 Tensile strength: 29.2 kN/m
 - .2 Creep reduced strength: 18.5 kN/m
 - .3 Long term allowable design load: 18.5 kN/m
 - .4 Grid aperture size (machine direction): 22.2mm
 - .5 Grid aperture size: 25.4mm
 - .6 Mass /unit area (ASTM D 5261): 254.3 g/m²
- 2.6 Geotextile**
- .1 Geotextile to be non woven polypropylene fabric, with the following properties:
- .1 Grab tensile strength: 167.8 kg
 - .2 Grab tensile elongation: 50%
 - .3 Mullen burst strength: 2,620 kPa
 - .4 Puncture strength: 58.97 kg
 - .5 Apparent opening size: US sieve 80 (0.180mm)
 - .6 Water flow rate: 3,870.8 l/min/m²
 - .7 Minimum roll width: 3600 mm
- 2.7 Granular Base**
- .1 Granular base and subbase to be as shown on Contract Drawings and to conform to Section 32.11.23 - Granular Base.
- 2.8 Backfill**
- .1 Backfill material adjacent to soil cells to be as shown on Contract Drawings.
- 2.9 Growing Medium**
- .1 Growing medium to be as shown on Contract Drawings and to conform to Section 32.91.21– Topsoil and Finish Grading.
- 2.10 Root Barrier**
- .2 Root barrier to be per Section 32.93.01 - Planting of Trees, Shrubs and Ground Covers - 2.15.

3.0 EXECUTION

3.1 Soil Cell Frame

- .1 Confirm that granular base meets compaction requirements of 95% of maximum dry density in accordance with ASTM D698 Standard Proctor method prior to placement of soil cell frame units. Grade sub-base surface on a plane parallel to the proposed finish grade above.
- .2 Identify tree openings, utility routes and edges of hard surfaces above soil cells on granular base using spiked string and/or spray paint.
- .3 Confirm that width and length of excavation are a minimum of 150mm beyond the edges of the Soil Cells. Layout location of all drain lines. Do not locate drain lines within 150mm of any Soil Cell post. Provide field engineering when drain lines are being installed to assure that the slope on all drains is 1% minimum towards intended outfalls. Place frame units by hand.
- .4 Place first layer of frame units on prepared and approved granular base and geotextile. Work away from tree and utility openings. Place frame units no less than 25mm apart and no more than 75mm apart.
- .5 Verify that horizontal and vertical position of frame units are consistent with required locations and dimensions of tree and utility openings, paving edges, surfaces and other structures to be constructed above soil cells. Report conflicts to Contract Administrator and make adjustments as necessary.
- .6 Ensure that each frame unit sits firmly on granular base. Ensure frames do not rock or bend over any stone or other obstruction and do not bend into dips in base.
- .7 Check each frame unit for damage prior to placing in excavation. Do not use frame units that are cracked or chipped
- .8 Secure soil cell to granular base with four anchor spikes driven through molded holes in base of frame unit.
- .9 For applications where soil cells are installed over waterproofed structures, develop a spacing system consistent with requirements of waterproofing system and do not use anchor spikes that will come within 150mm of any waterproofing material. Submit shop drawing of spacing and anchoring system for approval by Contract Administrator.
- .10 Do not walk on frame units.
- .11 Install next layer of frame units on top of previous layer. Build layers as stacks of frame units set one directly over the other.

Do not set frame unit half on one unit below and half on another unit.

- .12 Register each upper frame unit on top of lower frame unit post. Ensure contact points are free of dirt, mud and debris prior to placement. Ensure each upper unit is solidly seated on unit below. Rotate each frame registration arrow in the opposite direction from frame unit below to ensure connector tabs firmly connect.
- .13 Install no more than two layers of frame units before installation of growing medium and backfill.

3.2 Modified Soil Cell Frame

- .1 Install modified frame unit on top of frame unit prior to installation of growing medium and backfill.
- .2 Modified frame unit is required only during installation and compaction of growing medium and backfill.
- .3 Do not walk on modified frame units.
- .4 Remove modified frame unit prior to installation of deck unit and as installation of growing medium and backfill progresses across soil cell framework.
- .5 Remove modified frame unit prior to the installation of deck unit.
- .6 Place and remove modified frame units by hand.

3.3 Geogrid

- .1 Install geogrid curtain prior to installation of growing medium and backfill.
- .2 Geogrid curtain is required between edge of soil cell and any backfill or granular base beyond extent of soil cell framework that will support pedestrian or vehicular paving.
- .3 Install geogrid curtain where required. Do not install geogrid curtain between edge of soil cell and any planting area or tree opening adjacent to soil cell.
- .4 Pre-cut geogrid to allow for 150mm minimum underlap below backfill, and 300mm minimum overlap above soil cell deck.
- .5 Where soil cell layout causes a change of direction in plane of geogrid, slice top and bottom flaps of geogrid and fold so it lies flat on top of soil cell deck and granular base course along both planes.
- .6 Provide 300mm minimum overlap between different sheets of geogrid.

3.4 Growing Medium and Backfill

- .7 Secure geogrid to frame units and deck units with 4.5mm x 300mm plastic zip ties in locations recommended by manufacturer.
- .8 After deck unit is secured in place fold 300mm overlap of geogrid over top of unit.
- .1 Install root barrier as shown on Contract Drawings. Protect root barrier from damage and displacement during installation of growing medium and backfill.
- .2 Install growing medium and backfill as indicated on Contract Drawings. The process of installation requires that these two materials be installed and compacted together in alternating lifts to achieve correct compaction relationships between the materials.
- .3 Place growing medium in soil cell framework and spread by hand or hand tool through each soil cell in a maximum 200mm lift. Work soil under horizontal beams of soil cell frame and utility conduit to eliminate air pockets there. Ensure equipment bucket does not contact soil cell framework. Hold plywood sheet against geogrid during placement and compaction of growing medium to protect geogrid and maintain consistent separation of materials.
- .4 Finalize installation of utility conduit, drainage pipes and irrigation where shown on Contract Drawings.
- .5 Compact growing medium lift by stepping on entire exposed surface of growing medium. Do not step on frame units. Ensure there is a minimum of 250mm of growing medium over horizontal beams of frame units before beginning compaction. Leave top 50mm of frame unit exposed above growing medium to allow placement of next layer of frame units.
- .6 Compact growing medium to 85% of standard proctor density. Remove growing medium that is over compacted and reinstall.
- .7 Place backfill to 95% of maximum dry density in space between geogrid and sides of excavation and spread by hand adjacent to soil cell framework to provide maximum 200mm lift. Ensure geogrid under lap lays flat under backfill. Ensure equipment bucket does not contact soil cell framework. Hold plywood sheet against geogrid during placement and compaction of backfill to protect geogrid and maintain consistent separation of materials. Do not place backfill material in tree or planting bed opening.
- .8 Compact backfill per Contract Documents. Ensure compaction equipment does not contact soil cell frame or deck.

.9 Repeat placement and compaction of growing medium and backfill in lifts to top of topmost frame unit. Finish grade of growing medium to be 25mm below bottom of deck unit, except as indicated otherwise on Contract Drawings.

.10 Do not place final lift of backfill until adjacent deck unit is secured in place. Then install and compact backfill flush with soil cell deck. Ensure compaction equipment does not contact deck unit.

.11 Maintain modified frame unit in place until installation of deck unit.

3.5 Soil Cell Deck

.1 Obtain Contract Administrator's approval of placement and compaction of growing medium and backfill prior to installation of soil cell deck.

.2 Process for installation of deck units requires that deck units be installed immediately after removal of modified frame units.

.3 Remove modified frame unit.

.4 Ensure contact points are free of dirt, mud and debris prior to placement. Register deck unit on top of frame unit post. Do not set deck unit half on one frame unit below and half on another frame unit. Ensure deck unit is solidly seated on frame unit.

.5 Snap deck unit onto frame unit using snapping mechanism on corners of deck unit. A rubber mallet may be used to hammer snaps into place.

.6 Secure deck unit corners to frame unit posts using screws provided by manufacturer.

3.6 Geotextile

.1 Place geotextile over top of soil cell deck and where indicated on Drawings.

.2 Extend geotextile minimum 450mm beyond outside edge of excavation. Overlap geotextile joints minimum 450mm. Cut geotextile to provide minimum 200mm overlap of tree, planting and utility openings.

3.7 Inspection Assembly

Riser

.1 Install inspection riser assembly on top of geotextile in location shown on Contract Drawings immediately prior to placement of granular base. Maintain assembly in fixed position during placement of granular base and final hard surface treatment.

3.8 Geotextile

.1 Supply and install geotextile under soil cell system as shown on

Contract Drawings and per Section –31 32 19 - Geosynthetics.

- .2 Supply and install geotextile on soil cell deck as shown on Contract Drawings and per Section 31 32 19 - Geosynthetics.
- .3 Place geotextile over top of soil cell deck and where indicated on Drawings.
- .4 Extend geotextile minimum 450mm beyond outside edge of excavation. Overlap geotextile joints minimum 450mm. Cut geotextile to provide minimum 200mm overlap of tree, planting and utility openings.
- .5 Repair cut or damaged geotextile with a second piece of geotextile prior to placement of granular base. Overlap edges of cut or damaged area with second piece by a minimum of 300mm.

3.9 Granular Base

- .1 Supply and install granular sub-base course under soil cell system as shown on Contract Drawings and as specified in Section 32 11 23 - Granular Base.
- .2 Supply and install aggregate base course above soil cell system as shown on Contract Drawings and as specified in Section 32 11 23 - Granular Base.
- .3 Maximum tolerance for deviations in finished surface of granular base for soil cell system is 6mm over a 1200mm distance. Adjust granular base under each frame unit to provide a continuous solid base of support to required grade elevation.
- .4 Install granular base course on geotextile immediately after installation of geotextile.
- .5 Place granular base on soil cell system from one side of soil cell deck to other, to ensure geotextile and granular base conforms to cell deck contours.
- .6 Do not place or spread granular base in several positions at same time.
- .7 Load granular base onto soil cell system from equipment located outside limits of soil cell excavated area. Do not drive vehicles or operate equipment directly on top of soil cell deck, geotextile or granular base. Do not drive vehicles or operate equipment greater than 450kg directly on granular base over soil cell deck.
- .8 Spread granular base on soil cell system using hand tools or by light use of equipment bucket.

-
- .9 Compact granular base in lifts not to exceed 150mm, to 95% of maximum dry density. Compact granular base on top of soil cell system using walk behind type vibratory plate tamper, vibratory roller or jumping compacter having a maximum weight of 450kg.
- .10 For alternate method of placing and compacting granular base on top of soil cell system (e.g. for large area, small area, area of difficult access) submit shop drawing of proposed equipment and procedure to Contract Administration for approval.
- 3.10 Protection of Work**
- .3 Protect soil cell system, geotextile and granular base from vehicles, equipment, other materials and excessive moisture.
- .4 Use temporary fencing or hoarding to keep vehicles and equipment away off soil cell area until final surface materials are placed.
- 3.11 Clean Up**
- Dispose of surplus materials and all construction debris off site.

**1.9 Measurement
Payment**

and .1 Replace clause with:

“Payment for trees will be for each plant of the size and species specified on Contract Drawings. Payment includes tree supply, excavation and scarification of tree pits, tree placement, growing medium around rootball, tree pit mulching, edging, staking and guying as applicable and other incidentals as specified under Section 32.93.01 including maintenance until end of the Landscape Maintenance Period.”

.2 Replace clause with:

“Payment for shrubs, groundcovers, grasses, perennials and annuals will be for each plant of the size and species specified on Contract Drawings. Payment includes plant supply, excavation and scarification of planting pits, plant placement, growing medium around rootball and other incidentals as specified under Section 32.93.01 including maintenance to until end of the Landscape Maintenance Period.”

.3 Add clause:

“Payment for tree rings, tree grates, tree guards and tree boxes includes supply, preparation, finishing, installation, fittings, shop drawings and incidentals, as shown on Contract Drawing.”

.4 Add clause:

“Payment for root barrier will be for each type and size supplied and installed as shown on Contract Drawings.”

.5 Add clause:

“Payment for planting bed mulch includes supply and placement of mulch to specified thickness and hand or mechanical edging of mulched beds.”

2.1 Plant Material

.2.12 Replace clause with:

“All trees and plants to be inspected by Contract Administrator upon delivery to site and prior to planting.”

.3 Add clause:

“Submit written requests for plant material substitutions to the Contractor Administrator for review within 20 days of receiving Notice to Proceed. Provide explanation for requested substitution and evidence that the plant material is not available within 500km of the site.”

2.4 Mulch

.1 Replace clause with:

“Mulch to be ‘Glenmore Grow’, by City of Kelowna landfill operations, free of all soil, stones, sticks, roots or other extraneous matter.”

2.5 Stakes

.1 Replace clause with:

“Stakes to be as shown on Contract Documents.”

.2 Add clause:

“Where not otherwise shown on Contract Documents stakes to be pressure treated wood 50-70mm diameter approximately 2.0m long.”

2.6 Guying Collar

.1 Replace clause with:

“Acceptable products for guying collars and tree ties include the following:

- .1 Deep Root ArborTie series
- .2 Approved Equal”

2.13 Tree Rings, Grate, Frames, Guards and Boxes

Add clauses:

- “.1 Tree rings, grates, frames, guards and boxes to be as shown on Contract Documents.
- .2 Where not otherwise shown on Contract Documents tree rings, grates, frames, guards and boxes to be per Shop Drawing approved by Contract Administrator.”

2.15 Root Barrier

Add clauses:

- “.1 Acceptable root barrier products include the following:
 - .1 Deep Root UB series
 - .2 Approved Equal
- .2 Depth and length of root barrier product to be as shown on Contract Drawings.”

3.7 Mulching

.2 Replace clause with:

“Ensure minimum depth of mulch is 75mm after settlement.”

SUPPLEMENTARY SPECIFICATION CITY OF KELOWNA	IRRIGATION SYSTEM	SECTION 32 94 01S PAGE 1 OF 38
1.0	GENERAL	.1 Section 32 94 01S refers to those portions of the work that are unique to the complete installation of a fully automatic underground irrigation system, including all necessary preparatory work and all electrical, wiring and plumbing connections, and maintenance work during the guarantee period. This section must be referenced and interpreted simultaneously with all other sections pertinent to the works described herein.
1.1	Related Work	.20 Project Record Documents <u>Section 01 33 01</u> .21 Cast-in-Place Concrete <u>Section 03 30 53</u> .22 Precast Concrete <u>Section 03 40 -01</u> .23 Aggregates and Granular Materials <u>Section 31 05 17</u> .24 Topsoil and Finish Grading <u>Section 32 91 21</u> .25 Hydraulic Seeding <u>Section 32 92 19</u> .26 Seeding <u>Section 32 92 20</u> .27 Sodding <u>Section 32 92 23</u> .28 Planting of Trees, Shrubs and Ground Covers <u>Section 32 93 01</u>
1.2	References	.1 The abbreviated standard specifications for testing, materials, fabrication and supply, referred herein, are fully described in References - <u>Section 01 42 00</u> .
1.3	Codes and Permits	.1 Perform all work of this section in strict accordance with all municipal, provincial, or federal guidelines, regulations, and codes. Requirements of these specifications not conflicting therewith, exceeding code requirements govern. .2 Be responsible for obtaining all necessary permits and approvals required to undertake and complete the work. Include costs for required permits and approvals in tendered prices.
1.4	Quality Assurance	.1 Be a Certified Irrigation Contractor (CIC) with a minimum of 5 years of industry experience and a

member in good standing of one of the following organizations:

- .1 Irrigation Industry Association of British Columbia (IIABC)

- .2 The Irrigation Association (IA)

Provide documented proof of 5 years of industry experience, good standing membership in one of the above associations and CIC certification within 5 days of receipt of Notice to Proceed.

- .2 Be certified as a Field Safety Representative - Class LO, Low Energy Systems and registered with the British Columbia Safety Authority as an Electrical Contractor. Provide documented proof of same within 5 days of receipt of Notice to Proceed.

- .3 If the design involves HPDE, be certified in Plastic Pipe Fusion by the British Columbia Institute of Technology or an approved equivalent to fuse and install High Density Polyethylene Pipe. Provide documented proof of same within 5 days of receipt of Notice to Proceed.

- .4 All electrical components or products specified or used in construction of the proposed irrigation system must be CSA approved and installed in accordance with all local, provincial, and national electrical codes.

- .5 Install all irrigation components per manufacturer's recommendations, instructions and specifications. If unsure on how to install or use a specific product consult manufacturer to ensure proper installation and operation.

- .6 All materials to be new and without flaws.

- .7 All equipment specified and installed from various manufacturers to be compatible with existing equipment and other products specified for the irrigation system.

- .8 The completed system to efficiently and uniformly irrigate all areas and perform as required by these specifications.

-
- | | | | |
|-----|------------------------------|----|---|
| 1.5 | Scheduling and Shop Drawings | .1 | Ensure that sequencing of irrigation work is carried out in coordination with work of other trades and that sleeves, wire, pipes, valves and other equipment are installed when appropriate. |
| | | .2 | Plan, schedule and execute work to ensure a supply of water is available for landscape establishment and maintenance purposes at the appropriate time, in adequate amounts, and operating at design pressures to ensure satisfactory irrigation of all landscaped areas. |
| 1.6 | Substitutions | .1 | Where materials are specified by brand name and model number, such specifications will be deemed to facilitate a description of the materials and material quality and establish a standard for performance and quality against which proposed substitutes will be evaluated. |
| | | .2 | Proposed substitutes to match specified materials in, performance, flow, and pressure loss so as to not compromise the intent of the design or overall performance of the irrigation system. |
| | | .3 | Materials proposed as substitute products must meet or exceed the quality and performance of the specified materials. |
| | | .4 | Install and operate proposed substitutes according to their manufacturer's recommendations. |
| | | .5 | Include sufficient descriptive literature and product samples with proposed substitute to enable evaluation. |
| | | .6 | During the tender period proposed substitutions must be submitted to the Tender Administrator and the City of Kelowna at least 10 days prior to Tender Closing Date for consideration as an Approved Equal. |
| | | .7 | After contract award proposed substitutions submitted to the Contract Administrator and City of Kelowna after the tender period must be made within 5 days of Notice to Proceed and must allow 5 days for review. |
| | | .8 | Substitution requests by Contractor shall have no impact on the Milestone Date. |

- .9 Purchase or installation of materials that are not specified will not be paid for unless:
 - .1 The materials have been reviewed and approved by Contract Administrator and City of Kelowna as an Approved Equal as per Section 7.0, Instructions to Tenderers, or
 - .2 The materials have been reviewed and approved by Contract Administrator and City of Kelowna as a Change Order, per Section 7.3 of the General Conditions
 - .10 Installation of materials that are not specified or are not an Approved Equal to be removed and replaced with the specified material at Contractor's expense.
 - .11 Shop Drawings of irrigation system are required for any and all aspects of irrigation system not included in the Drawings. This includes but is not limited to:
 - .1 Revisions to irrigation system design not previously addressed in Contract Documents, including revisions to irrigation system design which markedly alter the original design, as determined by the City Engineer.
 - .2 Installation details for irrigation components not addressed in Contract Documents
 - .3 Details required by Contract Administrator for review of proposed substitutes
 - .4 Tasks identified in project specifications as requiring a Shop Drawing
 - .12 A revised Irrigation Design Report shall be required in tandem with Shop Drawings for revisions that markedly alter the original design, as determined by the City Engineer
 - .13 Submit Shop Drawing and revised Irrigation Design Report to Contract Administrator and City of Kelowna, for review, comment and approval or rejection.
- 1.7 Irrigation Drawings Record .1 Further to Schedule 3, maintain accurate scaled records

-
- of installed irrigation system and its components on a marked-up set of Contract Drawings on a daily basis during construction. Show all deviations from Contract Drawings. Make marked-up Contract Drawings available to Contract Administrator upon request.
- .2 Retain a qualified survey instrument operator to record exact location of all irrigation components as installed, including but not limited to:
 - .1 All irrigation surface components: e.g. sprinklers, valve locations, grounding point, controller components, wire splice boxes, valve boxes, vaults
 - .2 All irrigation sub-surface components: e.g. mainlines, laterals, pipe tees, ells, thrust blocks, pipe size changes, grounding components, sleeve ends
 3. Prepare surveyed Record Drawings. Clearly and legibly show all components of the irrigation system as installed. Identify each zone numerically, complete with precipitation rate and USgpm per zone. Prepare Record Drawings in digital (AutoCAD 2008 *.dwg and Adobe *.pdf) and hard copy formats
- 1.8 Operating Manual
- .1 Prepare a complete Operating Manual for installed irrigation system. Content of Operating Manual to include:
 - .1 Irrigation Design Report
 - .2 Equipment operating instructions
 - .3 Maintenance instructions including winterization and spring start up procedures
 - .4 Product literature
 - .5 Parts lists
 - .6 Irrigation watering schedule
 - .7 Two (2) sets of all keys and specialized tools or equipment required for commissioning, operation or maintenance of irrigation system
 - .8 Signed copies of irrigation inspection reports and test results

- .9 Copies of plumbing permit, electrical permit and low voltage certification
 - .10 Product warranty documentation for all controllers, meters, backflow prevention devices, valves, filters, sensors, electronic components and related irrigation components. Date the warranties with the date of Substantial Performance
 - .11 Written guarantee
- 1.9 Submittals
- .1 Submit complete set of Record Drawings to Contract Administrator prior to issuance of Certificate of Substantial Performance. Submit digital and hard copy Record Drawings in full size (22x34") and reduced (11x17") sizes, including one (1) laminated, 11"x17" copy of Record Drawings in controller cabinet.
 - .2 Submit complete Operating Manual to Contract Administrator prior to issuance of Certificate of Substantial Performance.
- 1.10 Measurement Payment for
- .1 Supply and installation of water service will be measured as a lump sum. The work includes:
 - .1 Permits and fees
 - .2 Supply, installation, testing and adjustment of the connection to water source and booster pump if required
 - .3 Master valve
 - .4 Water meter
 - .5 Flow sensor
 - .6 Backflow prevention device
 - .7 Blowout assembly
 - .8 Pressure reducing valve
 - .9 Filters

- .10 Vaults, valve boxes & lids
- .11 Fittings
- .12 Excavation, trenching, sleeves, backfill and restoration
- .13 All incidentals necessary for the proper installation and operation of a complete water service to the irrigation system
- .2 Supply and installation of electrical service will be measured as a lump sum. The work includes:
 - .1 Permits & fees
 - .2 Electrical meter
 - .3 Supply, installation and testing of the connection to electrical source
 - .4 Excavation, trenching, conduits, backfill and restoration
 - .5 All incidentals necessary for the proper installation and operation of a complete electrical service to the irrigation system
- .3 Supply and installation of irrigation control system will be measured as a lump sum. The work includes
 - .1 Permits & fees
 - .2 Supply, installation, testing, programming, and adjustment of irrigation system controller
 - .3 Transmitters & decoders
 - .4 Electrical conduits
 - .5 Controller cabinets
 - .6 Vaults, valve boxes & lids
 - .7 Fittings
 - .8 Excavation, trenching, backfill, and restoration

- .9 All incidentals necessary for the proper installation and operation of a complete irrigation control system
- .4 Supply and installation of pipes, valves, sprinklers and dripline will be measured as a lump sum. The work includes but is not limited to:
 - .1 Supply, installation, testing and adjustment of irrigation pipe
 - .2 Sleeves and conduit,
 - .3 Zone control valves
 - .4 Micro-irrigation control zone kits
 - .5 Electric control wire, common wire, flow sensor wire, and spare wires
 - .6 Drain valves
 - .7 Isolation valves
 - .8 Pressure regulators
 - .9 Swing joint assemblies
 - .10 Sprinklers
 - .11 Emitters, bubblers, dripline, and root watering systems
 - .12 Air / vacuum relief valves
 - .13 Fittings
 - .14 Vaults, valve boxes & lids
 - .15 Excavation, trenching, backfill and restoration
 - .16 All incidentals necessary for the proper installation and operation of a complete irrigation system
- .5 Payment for Record Drawings and Operating Manual will be measured as a lump sum.
- .6 Payment for irrigation system tests, inspections,

maintenance, winterization and spring start-up during the warranty period will be incidental to the work under this section.

- 1.11 Tests and Inspections
- .1 Refer to General Conditions, Clause 4.12, Tests and Inspections.
 - .2 At various milestones during construction inspection and testing of components will be required to ensure performance of irrigation system meets expected standards.
 - .3 Provide equipment and personnel necessary for performance of inspections and tests.
 - .4 As a condition of issuance of Certificate of Substantial Performance confirm in writing to the City of Kelowna, at least one week prior to application for Substantial Performance, the following inspections and successful tests:
 - .1 Certified backflow prevention device test per BCWWA.
 - .2 Mainline pressure test
 - .3 Ground grid connection inspection and earth ground test
 - .4 System coverage and operation test
 - .5 Dripline/emitter inspection and test, if applicable
 - .6 HDPE pipe strap test if applicable
 - .7 Vault drainage test
 - .5 Conduct all inspections and tests in presence of Contract Administrator and request Contract Administrator issue signed report to Contractor within three days regarding each test result. Request attendance of Contract Administrator for proposed inspection or test at least 3 days prior to proposed inspection or test.

SUPPLEMENTARY SPECIFICATION CITY OF KELOWNA	IRRIGATION SYSTEM	SECTION 32 94 01S PAGE 10 OF 38
--	--------------------------	--

- | | | | |
|------|---------------------------------|-----|--|
| | | .6 | Keep work uncovered and accessible until successful completion of inspection or test. |
| 1.12 | Backflow Prevention Device Test | .1 | Conduct backflow prevention device test per American Water Works Association standard using qualified personnel. |
| 1.13 | Mainline Pressure Test | .1 | Perform mainline pressure test to identify potential leaks and ensure mainline is able to operate at design pressure and maintain system pressure. |
| | | .2 | Conduct mainline pressure test prior to backfilling of mainline. |
| | | .3 | Fill mainline with water and expel all air from pipe. Maintain water in pipe as follows: |
| | | .1 | 24 hours for PVC mainline |
| | | .2 | 3 hours for HDPE mainline |
| | | .4 | Subject mainline to hydrostatic pressure of 150psi or twice the optimum design operating pressure of the mainline and not to exceed 200psi. |
| | | .5 | Stop supply of make-up water to mainline and record hydrostatic pressure in mainline. |
| | | .6 | Visually inspect mainline and fittings for leaks. |
| | | .7 | Record hydrostatic pressure in mainline 3 hours after supply of make-up water stopped. |
| | | .8 | Determine test result based on difference in recorded pressures at beginning and end of test as follows: |
| | | .1 | Passed test: Less than 5% difference |
| | | .2 | Failed test: Difference of 5% or greater |
| | | .9 | Identify source of leak and replace any and all defective materials and workmanship as necessary to eliminate leak. |
| | | .10 | Repeat mainline pressure test and make replacements as necessary until a passed result is achieved. |

-
- 1.14 **Ground Grid
Connection Inspection
and Earth Ground
Test**
- .1 Conduct ground grid connection inspection and earth ground prior to operation of irrigation controller.
 - .2 Visually inspect all Cad Weld connections or approved equal to ensure AWG #6 single strand copper ground wire is securely bonded to copper ground rods or plates.
 - .3 Connect Earth Ground Tester (Megger) to AWG #6 single strand copper ground wire(s) per manufacturer's recommendations.
 - .4 Conduct earth ground test per recommendations of irrigation controller manufacturer.
- 1.15 **System Coverage and
Operation Test**
- .1 Conduct system coverage and operation test after installation and operation of complete irrigation system and prior to issuance of Certificate of Substantial Performance.
 - .2 Conduct visual inspection to confirm that:
 - .1 Head spacing does not exceed that shown on Contract Drawings
 - .2 Where applicable, irrigation piping should be designed to follow the contours of the land in an effort to minimize low head drainage situations.
 - .3 Heads, boxes, vaults and trenches are at specified elevation relevant to finished grade and not subject to settlement or lifting
 - .3 Conduct operational tests to verify that:
 - .1 Controller can be programmed manually on site and remotely via Owner's central irrigation control system
 - .2 Controller can send and receive communication with Owner's central irrigation control system 10 consecutive times without a missed communication
 - .3 Controller responds to flow sensor

- .4 Operating pressure is within design parameters
 - .5 Each zone can be operated automatically and in succession via programmed controller
 - .6 Performance provides head to head coverage
 - .7 There is no overspray onto different control zones, hard surfaces or other improvements
- 1.16 Dripline/Emitter Inspection
- .1 Perform inspection and testing of dripline/emitter manifold and lines to identify potential leaks and confirm manifold, driplines and emitters are able to operate at design pressure. Conduct inspection and testing prior to backfilling of manifold, driplines or emitters.
 - .2 Fill manifold and lines with water at operating pressure and maintain pressure for 1 hour. Visually inspect manifold, driplines and fittings for leaks. Confirm that emitters are functioning correctly. Identify sources of leaks and replace any and all defective materials and workmanship as necessary to eliminate leak.
 - .3 Repeat inspection and testing and make replacements as necessary until no further leaks are identified.
- 1.17 HDPE Pipe Strap Test
- .1 Conduct HDPE pipe strap test at least 1 hour after fusion weld has been made and prior to backfilling of HDPE pipe on those fusion welds where, upon visual or tactile inspection, the bead does not roll back properly or is not consistent in height or width.
 - .2 HDPE pipe strap test consists of:
 - .1 Cut fusion weld from pipe, allowing 200mm on either side of weld to work with
 - .2 Cut pipe lengthways through fusion weld to create a strap 25mm wide
 - .3 Bend strap back on itself

- .4 If weld breaks repeat test on another fusion weld, chosen by Contract Administrator. If second fusion weld fails then all welds become suspect and the HDPE pipe cannot be installed until the reason for the fusion joint failures is determined
 - .5 If fusion weld does not break then weld is acceptable and no further testing of similar welds is required
 - .6 Replace or repair tested pipe strap
- 1.18 Vault Drainage Test
- .1 Conduct vault drainage test when vault is installed and backfilled and prior to installation of backflow prevention device and water supply line in vault.
 - .2 Fill point of connection vault with water to a depth of 300mm and leave water to drain.
 - .3 Determine test result based on time required for water to drain below finish grade of drain rock in bottom of vault:
 - .1 Passed test: 1 hour or less
 - .2 Failed test: Greater than 4 hours
- 2.0 PRODUCTS
- 2.1 Water Service and Meter
- .1 Unless already installed or otherwise required by the water utility having jurisdiction over the site provide a metered water service, including but not limited to:
 - .1 Plumbing permit
 - .2 Backflow prevention device; with permit as required
 - .3 Establishment and verification of water account with appropriate utility provider
 - .2 Supply and install water meter in accordance with requirements of water utility.

-
- .3 Conform size of water meter to mainline diameter and allow for minimal pressure losses.

 - 2.2 Electrical Service and Meter
 - .1 Unless already installed or otherwise required by the electrical utility having jurisdiction over the site provide a metered electrical service, including but not limited to:
 - .1 Electrical permit
 - .2 Electric meter
 - .3 Establishment and verification of electrical account with appropriate utility provider
 - .2 Type and size of electrical service to be as specified on Contract Drawings.
 - .3 Unless specified otherwise electric meter to be supplied and installed per standards and specifications of electrical utility.

 - 2.3 Isolation Valve
 - .1 Acceptable isolation valves include the following:
 - .1 Up to 2" see Approved Products List
 - .2 Greater than 2" per Contract Drawings

 - 2.4 Flow Sensor
 - .1 Flow sensors impellers to be brass or stainless steel for up to 1" size, and glass filled nylon over 1" size, sized to match system low and high flows.
 - .2 Acceptable wire for flow sensor to be shielded, direct burial instrument cable and includes the following:
 - .1 Beldan
 - .2 Approved Equal

 - 2.5 Master Valve
 - .1 Acceptable master valves are specified on the Approved Products List.
 - .2 Ensure master valve is sized to maximum and minimum flow parameters shown on Contract Drawings.

SUPPLEMENTARY SPECIFICATION CITY OF KELOWNA	IRRIGATION SYSTEM	SECTION 32 94 01S PAGE 15 OF 38
2.6	Pressure Valve Reducing	.1 Acceptable water pressure reducing valves are specified on the Approved Products List.
2.7	Backflow Prevention Device	.1 Acceptable double check valve assemblies (DCVA) are specified on the Approved Products List. .2 Acceptable Reduced Pressure Backflow Assemblies (RPBA) are specified on the Approved Products List.
2.8	Blowout Assembly	.1 Blowout assembly to be 50mm brass gate valve with brass hydrant adapter and threaded cap on swing joint assembly.
2.9	Vault and Lid	.1 Acceptable vaults and matching lids for point of connection equipment and components are dependent on service size and include the following: .1 ¾" one (1) KonKast 1031 vault with Excel 4840-1 lid .2 1" to 2" one (1) KonKast 1102 with Excel 3974-2 lid .3 2 ½" to 3" two (2) KonKast 1102 with Excel 3974-2 lid .4 Larger than 3" per Contract Drawings .2 Lids to have recessed hinges and locking hardware.
2.10	Vault Drain	.1 Perforated Schedule 40 PVC pipe, 4" diameter, with threaded inlet cover having maximum 13mm grated openings.
2.11	Ground Assembly	.1 Ground assembly consists of CSA and BC Electrical Code endorsed products per irrigation controller manufacturer's recommendations for grounding.
2.12	Irrigation Controller	.1 Irrigation controller and associated components per Drawings.
2.13	Pulse Decoder	.1 Acceptable pulse decoders are specified on the Approved

SUPPLEMENTARY SPECIFICATION CITY OF KELOWNA	IRRIGATION SYSTEM	SECTION 32 94 01S PAGE 16 OF 38
	Products List.	
2.14	Pulse Transmitter Output	.1 Acceptable pulse output transmitters are specified on the Approved Products List.
2.15	Controller Cabinet	.1 Acceptable controller cabinets by Kelowna Steel Fabricators and include the following: <ul style="list-style-type: none"> .1 Double post # KSH-21 .2 Irrigation cabinet to be finished using: <ul style="list-style-type: none"> .1 One coat of Zinc Chromate Primer (General Paint or Tremclad) .2 Two coats of General Paint Exterior Alkyd #CW033W .3 Cabinet hinges to allow for grease application.
2.16	Electric Control Valve	.1 Acceptable electric control valves are specified on the Approved Products List. <ul style="list-style-type: none"> .2 Size electric control valve in accordance with valve manufacturer's recommendations for the design flow. .3 Include pressure regulating modules as required to provide the optimum operating pressure for each irrigation circuit and head/outlet specification. .4 Acceptable manufacturers of control zone kits for drip irrigation are specified on the Approved Products List. .5 Size control zone kit for drip irrigation based on zone flows. Refer to manufacturers recommendations to specify the suitable control zone kit.
2.17	Manual Control Valve	.1 Acceptable manual control valves include the following: <ul style="list-style-type: none"> .1 Up to 2" see the Approved Products List .2 Greater than 2" per Contract Drawings
2.18	Pressure Module Regulating	.1 Acceptable pressure regulating modules are specified on the Approved Products List.

SUPPLEMENTARY SPECIFICATION CITY OF KELOWNA	IRRIGATION SYSTEM	SECTION 32 94 01S PAGE 17 OF 38
		<ul style="list-style-type: none"> .2 Size in-line pressure regulating module per manufacturer's recommendations for drip irrigation application. .3 Ensure pressure regulating module is compatible with control valve of zone it is installed on.
2.19	Low Flow Control Valve	.1 Acceptable low flow control valves for drip zones are specified on the Approved Products List.
2.20	Low Flow Filter	<ul style="list-style-type: none"> .1 Acceptable low flow filter for drip zones are specified on the Approved Products List. .2 Filter to be commercial grade filter appropriate for low flow rates and with an external indicator showing of filter is clean or dirty.
2.21	High Flow Filter	.1 Acceptable high flow filter for irrigation system are specified on the Approved Products List.
2.22	Quick Coupler Valve	.1 Acceptable quick coupler valves are specified on the Approved Products List.
2.23	Swing Joint Assembly	<ul style="list-style-type: none"> .1 Fabricated with three threaded Schedule 40 PVC elbows and one threaded Schedule 80 PVC nipple. .2 Length of nipple shall be such a length to permit installed head or valve to be set as specified. .3 Diameter of nipple to match inlet for valve or head shown on Contract Drawings.
2.24	Lateral Flush Cap	.1 Ball valve with street elbow and flexible hose on swing joint assembly.
2.25	Valve Box	<ul style="list-style-type: none"> .1 Irrigation valve boxes are specified on the Approved Products List. .2 Valve box and matching lid and extensions to be commercial grade and green in colour.

SUPPLEMENTARY SPECIFICATION CITY OF KELOWNA	IRRIGATION SYSTEM	SECTION 32 94 01S PAGE 18 OF 38
		.3 Valve box to have locking lid with stainless steel bolt locking device and appropriate washers.
2.26	Control Wire	<ul style="list-style-type: none"> a. Control wire from irrigation controller to electric control valve to be minimum #14 gauge, direct burial, type TWU-40 wire. Control wire to be any colour other than white, blue, purple or red. b. Common wire from irrigation controller to electric control valve to be minimum #12 gauge direct burial, type TWU-40 wire. Common wire to be white in colour. c. Master valve wire from the controller to valve to be minimum #14 gauge direct burial, type TWU-40 wire. Wire to be red in colour. d. Spare control wire to be blue in colour. e. Spare common wire to be white in colour. f. All connectors to be new, two-step, CSA approved for water tight applications and assembled according to the manufacturer's recommendations.
2.27	Wire Splice Box	<ul style="list-style-type: none"> .1 Wire splice boxes and lids boxes are specified on the Approved Products List. .2 Wire splice box and matching lid and extensions to be commercial grade and grey in colour. Wire splice box to have locking lid with stainless steel bolt locking device and appropriate washers
2.28	Irrigation Sleeve	<ul style="list-style-type: none"> .1 Class C-900 PVC for irrigation sleeve in bored hole or under hard surface. .2 Irrigation sleeve diameter to be minimum 4" or twice the diameter of main or lateral line running through it, whichever is greater. .3 Control wire conduit to be a minimum 2" diameter electrical conduit, per code.
2.28	Polyvinyl Chloride (PVC) Pipe	<ul style="list-style-type: none"> .1 Conform to CSA B137.3-93. .2 New condition, extruded form virgin, high impact

materials, solvent weldable with belled ends, continually and permanently marked showing manufacturer's name, material, size, pressure rating, and CSA approval.

.3 PVC pipe to be as follows:

.1 Class 200 PVC pipe for pipe sizes ¾" to 2¼" in diameter

.2 Bell & Spigot gasket joint pipe c/w concrete thrust blocking for pipe sizes 2½" in diameter and greater

2.30 Polyethylene Pipe (PE) .1 New condition CSA Series 100, MDPE in new condition, extruded from virgin materials, continually and permanently marked showing manufacturers name, material, size, and pressure rating.

2.31 High Polyethylene Pipe Density (HDPE) .1 New condition CSA Approved, extruded from virgin materials, continually and permanently marked showing manufacturers name, material, size, and pressure rating.

.2 Material to be listed by the Canadian Standards Association (CSA) and Plastic Pipe Institute (PPI) as a PE-3408 resin with a hydrostatic design basis (HDB) of 1600psi for water at 23°C. Material to comply with ASTM D-1248 as a Type III Class C, Category 5, Grade P34 material and with ASTM D-3350 as a 345434C cell material.

.3 Acceptable HDPE pipe is dependent on operating pressure and to have Standard Density Ratios (SDR) as follows:

.1 Max. pressure up to 100psi: SDR-17.0

.2 Max. pressure exceeding 100psi: SDR-11.0

2.32 Fittings .1 New condition Schedule 40 PVC conforming to ASTM D-2466-97 (and F438-97 for CPVC) standards and of the same material as pipe. Fittings to be designed for solvent welding to PVC pipe except where valves and risers require threaded joints.

-
- .2 Nipples to be threaded Schedule 80 PVC and manufactured from same material as the pipe.
 - .3 At the point where the supply source changes from metal to PVC pipe, the metal end of the pipe must be an FIPT (female) adapter and the PVC fitting a MIPT (male) adapter.
 - .4 Flange couplers may be used upon approval of Contract Administrator.
 - .5 Fittings for HDPE pipe to be Schedule 80 PVC insert fittings complete with stainless steel gear clamps.
 - .6 Fittings for HDPE pipe to be butt fusion type for end-to-end joints.
 - .7 SDR rating of HDPE fittings must match the SDR rating of the HDPE pipe specified.
 - .8 HDPE pipe fittings to be molded or fabricated by the pipe manufacturer. HDPE pipe fittings and flange adapters made by contractors or distributors are prohibited.
 - .9 Fittings for dripline and drip emitters to be compatible with specified dripline or emitter and as recommended by manufacturer.
- 2.33 Pipe Solvent and Primer
- .1 PVC pipe solvent and primer combinations recommended by manufacturer and suitable for use with specified materials and application.
 - .2 Use solvent and primer as directed by manufacturer. Use only solvent and primer that meets local codes.
 - .3 Primer for cleaning pipe and fittings to be P70 or P72 and compatible with solvent used.
 - .4 The use of wet and dry solvent and primer is prohibited.
- 2.34 Copper Pipe and Fittings
- .1 Copper pipe and fittings per BC Plumbing Code per applicable use.

SUPPLEMENTARY SPECIFICATION CITY OF KELOWNA	IRRIGATION SYSTEM	SECTION 32 94 01S PAGE 21 OF 38
		.2 All pipe and fittings installed in mechanical rooms, parkades, or routed through the interior of buildings to be copper.
2.35	Brass Pipe and Fittings	.1 Brass pipe and fittings per BC Plumbing Code per applicable use. .2 All pipe and fittings installed irrigation vault to be brass per Drawings.
2.36	Thrust Block	.1 Thrust blocks to be 20MPa at 28 day strength. Thrust blocks can be either: .1 Poured in place concrete .2 Pre-cast concrete block .2 Size and shape of the concrete thrust block will depend on type of joint, size of pipe, width of trench, and type of soil, per Drawings
2.37	Sprinklers - General	.1 Make, model, nozzle size, and features of sprinklers as specified on Contract Drawings. .2 All sprinklers installed in sport field turf areas to be equipped with the manufacturer-supplied rubber covers.
2.38	Sprayhead Sprinkler	.1 Acceptable sprayhead sprinklers are specified on the Approved Products List. .2 Required pop-up height for sprayhead sprinklers to be as shown on Contract Drawings.
2.39	Rotor Sprinkler	.1 Acceptable rotor sprinklers are specified on the Approved Products List.
2.40	Dripline	.1 Dripline shall incorporate root intrusion technology and be as shown on Contract Drawings. .2 Pressure compensating driplines are specified on the Approved Products List.

SUPPLEMENTARY SPECIFICATION CITY OF KELOWNA	IRRIGATION SYSTEM	SECTION 32 94 01S PAGE 22 OF 38
2.41	Drip Emitter/Bubbler	.1 Drip emitters/bubblers shall be as shown on Contract Drawings.
		.2 Drip emitters/bubblers are specified on the Approved Products List.
2.42	Sand	.1 Sand to be pit run sand, per <u>Section 31.05.17</u> .
2.43	Drain Rock	.1 Drain rock to be drain rock, per <u>Section 31.05.17</u> .
2.44	Water	.1 Free of impurities that would inhibit germination and growth or may be harmful to people or the environment.
		.2 Test water from sources other than treated potable water for suitability in irrigation to determine that it meets the requirements of this section.
3.0	EXECUTION	
3.1	Existing Conditions	.1 Report existing conditions at variance with Contract Drawings to Contract Administrator.
		.2 Verify locations of underground utilities prior to commencing excavation and conduct work so to prevent interruption and damage to services and utilities. Make good all damages to same at Contractor's cost.
		.3 Verify location of all services in building walls before boring or drilling holes. Make good all damages to same at Contractor's cost.
		.4 Protect existing conditions and completed work from disturbance during Work. Make good all damages to same at Contractor's cost.
		.5 Adjustments to installation of irrigation system to avoid existing conditions, completed work and utilities will be permitted subject to prior approval by Contract Administrator.
3.2	Layout	.1 Locations of irrigation components shown on plans is schematic in nature. Coordinate actual location of irrigation components with landscaping, building and physical features of site. Confirm proposed changes to

location of irrigation components in writing with Contract Administrator prior to installation. Changes that markedly alter the irrigation design in the opinion of the City Engineers require submission of Shop Drawings and updated Irrigation Design Report to City of Kelowna for their permission to proceed. Record all approved revisions on a marked-up set of Contract Drawings

.2 Layout and stake irrigation system per Contract Drawings to confirm:

.1 Layout is within project boundary and property lines

.2 Site grades are consistent with Contract Drawings

.3 Damage to root system of existing trees is minimized

.4 Installation of irrigation components to be a minimum of 1 meter outside the dripline of existing trees

.5 Minimum horizontal and vertical clearances from electrical and other utilities are met

.6 Location of all sleeving, main lines, cabinets, vaults, valve boxes, splice boxes and ground grid assembly

.3 Have layout inspected and approved by the Contract Administrator before commencement of work. Adjust layout as instructed by Contract Administrator.

.4 During construction it may be necessary to adjust the layout of the irrigation system. Request layout changes to Contract Administrator prior to execution of work.

.5 Do not modify irrigation layout without written approval of Contract Administrator.

3.3 Excavation

.1 Excavate to ensure depth and bedding requirements are met.

.2 All excavation is unclassified. Report any material or site condition that cannot be excavated by normal

-
- mechanical or manual means or that may affect excavation to required depth to Contract Administrator prior to excavation.
- .3 Identify and recycle all suitable materials recovered during construction.
- .4 Remove and dispose of buried debris exposed during excavation, including decommissioned irrigation materials and underground utilities, which may impede the proper installation and operation of irrigation system.
- 3.4 Water Service and Account
- .1 Establish water utility account and obtain permits and approvals necessary to install and operate irrigation system.
- .2 Review regulations and restrictions imposed by applicable water utility with Certified Irrigation Designer and advise Contract Administrator of any regulations or restrictions that will affect operation of proposed irrigation system. Provide Contract Administrator with options necessary to respond to any regulations or restrictions affecting operation of proposed irrigation system.
- .3 Coordinate with water utility as required to confirm availability, suitability, and location of an acceptable service connection.
- .4 Isolate water service prior to installation of any irrigation components.
- .5 Install water service to point of connection with additional isolation valves similar to SS-W50.
- 3.5 Electrical Service and Account
- .1 Within 5 days of receipt of Notice to Proceed provide Contract Administrator with information necessary for Owner to make application to electrical utility for service connection.
- .2 Obtain permits and approvals necessary to install and operate irrigation system.
- .3 Coordinate with electrical utility as required to confirm the availability, suitability, and location of an

			acceptable service connection.
		.4	Install all electrical connections in accordance with local, provincial and national electrical codes.
		.5	Install 120v AC on opposite side of the mainline trench from 24v AC irrigation control / communication wires to prevent "cross talk" from a higher voltage. Where 120v AC cable is not installed adjacent to irrigation mainline install it in non-metallic electrical conduit.
3.6	Water Meter	.1	Install water meter per Drawings and requirements of water utility.
3.7	Isolation Valve	.1	Install isolation valve per Drawings.
3.8	Flow Sensor	.1	Install flow sensor in location specified on Drawings.
		.2	Flow sensor wire to run continuously, with no splices, between flow sensor and irrigation controller.
		.3	Follow manufacturer's recommendations for installation and wiring of flow sensor.
3.9	Master Valve	.1	Install master valve per Drawings.
3.10	Pressure Reducing Valve	.1	Install pressure reducing valve (PRV) per manufacturer's recommendations in location shown on Contract Drawings and as required to maintain operating pressure within manufacturer's recommended range.
		.2	Adjust PRV to provide water at design pressure for the sprinkler furthest from control valve.
3.11	Backflow Prevention Device	.1	Install Double Check Valve Assembly (DCVA) in lockable concrete vault or a locked mechanical room, per Drawings.
		.2	Install Reduced Pressure Backflow Assembly (RPBA) a minimum of 300mm above finished grade per manufacturer's recommendations and Drawings . Install RPBA on reinforced concrete pad with pipe

- restraints bolted to floor to restrain and support assembly.
- .3 Construct reinforced concrete pad for RPBA 150mm larger than the proposed enclosure in all directions. Construct reinforced concrete pad on a 150mm thickness of granular base compacted to 95% S.P.D. Provide vault drain directly below discharge valve and connect to drain pit, dry well, manhole or catch basin.
 - .4 Install acceptable lockable enclosure over the RPBA large enough to secure the assembly and any associated components attached to this point.
 - .5 Install backflow prevention device in accordance with all applicable codes and bylaws and in accordance with the current Cross Connection Control Manual Accepted Procedure and Practice (American Water Works Association).
 - .6 Install backflow prevention devices with positive drainage and room for maintenance and servicing.
 - .7 Support backflow prevention device with specified supports per manufacturer's recommendations for locations of the support points.
- 3.12 Blowout Assembly
- .1 Install blowout assembly per Drawings.
- 3.13 Vault and Lid
- .1 Install vault in location shown on Contract Drawings or in alternate location approved or directed by Contract Administrator.
 - .2 Support and brace point of connection components, piping and valves within vault using adjustable aluminium pipe stands complete with riser, pipe clamps, base plate and galvanized or stainless steel fittings in the quantity per service size indicated as follows:
 - .1 ¾" 2 supports
 - .2 1" to 2" 3 supports
 - .3 2 ½" to 3" 3 supports per vault
 - .4 Larger than 3" per Contract Drawings

-
- .3 Lids to have recessed hinges and locking hardware.
 - .4 Use brass pipe for all piping inside vault and extend brass piping outside the vault a minimum of 300mm beyond vault. Make union of brass pipe with other pipe in valve box or vault using specified fitting.
 - .5 Make connections of PVC pipe and metal pipe using male threads on PVC pipe and female threads on metal pipe.
 - .6 Install vault drain and connect to drain pit, dry well, manhole or catch basin.
- 3.14 Ground Assembly
- .1 Install ground assembly in location shown on Contract Drawings or the revised location approved by the Contract Administrator.
 - .2 Use the rod, plate and wire configuration as recommended by manufacturer of irrigation controller and per BC Electrical Code.
- 3.15 Irrigation Controller
- .1 Install irrigation controller in controller cabinet.
 - .2 Coordinate controller installation with that of other electrical components.
 - .3 Install controller and wiring in accordance with local, provincial and national electrical codes.
 - .4 Install and test the ground assembly using a "Megger" to ensure earth resistance to ground does not exceed controller manufacturer's recommendations.
 - .5 Install communication components per manufacturer's recommendations and establish communication between controller and Owner's central irrigation control system, including relays or boosters as necessary.
 - .6 Prior to issuance of Certificate of Substantial Performance request irrigation program from Contract Administrator and set controller program accordingly.
- 3.16 Pulse Decoder
- .1 Install pulse decoder in controller cabinet per

				manufacturer's recommendations.
3.17	Pulse Transmitter	Output	.1	Install pulse output transmitter in controller cabinet per manufacturer's recommendations.
3.18	Controller Cabinet		.1	Install controller cabinet in location shown on Contract Drawings or in alternate location approved or directed by Contract Administrator.
			.2	Orient alignment of controller cabinet as approved by Contract Administrator to provide optimal observation of irrigation system in operation.
			.3	Install controller cabinet using a poured in place concrete pad mount.
			.4	Provide electrical service to controller cabinet as shown on Contract Drawings.
			.5	Install electric meter in the irrigation cabinet per electrical utility's requirement.
			.6	Install only GFI breakers in controller cabinet electrical panel.
			.7	Install 1 duplex 120v AC GFI receptacle, on dedicated breaker, in controller cabinet.
3.19	Electric Control Valve		.1	Install in valve box per manufacturer's recommendations and Drawings .
			.2	Identify electric control valve with permanent label or tag indicating zone number of valve.
3.20	Manual Control Valve		.1	Install in valve box per manufacturer's recommendations and Drawings.
			.2	Identify manual control valve with permanent label or tag indicating zone number of valve.
3.21	Pressure Regulating Module	Regulating	.1	Install pressure regulating module in same valve box as low flow control valve, per manufacturer's recommendations and Drawings.

-
- | | | | |
|------|------------------------|----|---|
| | | .2 | Adjust pressure regulating module to provide water at design pressure for head, emitter or end of dripline farthest from control valve. |
| 3.22 | Low Flow Control Valve | .1 | Install low flow control valve in valve box at beginning of each drip irrigation zone, per manufacturer's recommendations and Drawings. |
| | | .2 | Identify low flow control valve with permanent label or tag indicating zone number of valve. |
| 3.23 | Low Flow Filter | .1 | Install low flow filter in same valve box as low flow control valve, per manufacturer's recommendations and Drawings . |
| 3.24 | Quick Coupler Valve | .1 | Install per manufacturer's recommendations in valve box per Drawings . |
| | | .2 | Install quick coupler valve on swing joint assembly in upright plumb position. |
| | | .3 | Install non-corrosive metal clamp on quick coupler valve to prevent uninhibited turning of the valve. |
| | | .4 | Do not install quick coupler in same valve box as electric control valve. |
| 3.25 | Swing Joint Assembly | .1 | Fabricate assembly of triple swing joint using three threaded Schedule 40 PVC elbows and one threaded Schedule 80 PVC nipple. |
| | | .2 | Install swing joint assembly to rotate clockwise when depressed. |
| | | .3 | Tape threads of PVC fittings with Teflon tape and make hard hand tight. |
| 2.26 | Lateral Flush Cap | .1 | Install lateral flush cap on swing joint assembly in valve box. |
| | | .2 | Coil hose in valve box. |

- 3.27 Valve Box
- .1 Install all manual and electric control valves, control zone kits and quick coupler valves in valve boxes or concrete vault as shown on Drawings.
 - .2 Except as shown otherwise on Contract Drawings or approved otherwise by Contract Administrator, locate valve boxes in planting beds and locate for ease of access, maintenance, and testing.
 - .3 Install valve box flush with finish grade and arrange in a neat and orderly manner.
 - .4 Provide minimum 150mm clearance between valve box and all components within.
 - .5 Valve box must not contact irrigation pipe. Use 150mm height matching valve box extensions as required.
 - .6 Up to three 1" control valves or two 1½" control valves may be contained within a single valve box provided there is 100mm of clearance between valves. Install valve 2" and larger in their own valve box.
- 3.28 Control Wire
- .1 Install control wire per code and by qualified personnel employed by the company holding the electrical permit.
 - .2 Bury control wire per applicable code and in no case above the bottom side of parallel pipe.
 - .3 Bed control wire in sand with minimum 50mm sand around control wire. Where control wire is in same trench as pipe, place wire beside pipe with horizontal clearance of a minimum of 50mm and in accordance with BC Electrical Code depth.
 - .4 Bundle multiple lengths of wire in same trench or conduit with ties at maximum 3.0m intervals.
 - .5 Install wire with minimum 600mm length of coiled slack at all changes of direction, in wire splice boxes and at connections to controlled components.
 - .6 Identify all control wires entering controller cabinet with permanent label or tag indicating zone number of valve operated by each control wire.
 - .7 Maintain consistent wire colour through wire splice box.

-
- .8 Minimize wire splices. Where wire splices are unavoidable make splice only in wire splice box using specified connector.
 - .9 Identify spliced wire with permanent label or tag indicating zone number of spliced control wire.
 - .10 Where specified on Contract Drawings, install extra control wire to wire splice box. Provide 600mm length of coiled slack of each wire end in wire splice box. Identify extra control wire as 'extra' wire with permanent label or tag.
- 3.29 Wire Splice Box
- .1 Locate wire splice box in planting bed where possible and locate for ease of access, maintenance, and testing.
 - .2 Install wire splice box per Drawings and arrange in a neat and orderly manner.
 - .3 Do not install valves in wire splice box.
- 3.30 Irrigation Sleeve
- .1 Install irrigation sleeves in locations shown on Contract Drawings.
 - .2 Install irrigation sleeve to depth as follows:
 - .1 Mainline Piping
 - .1 600mm below walkways
 - .2 750mm below driveways, roads and plazas
 - .2 Lateral Piping
 - .1 300mm below walkways
 - .2 600mm below driveways, roads and plazas
 - .3 Install sleeve to extend 1.0m past edge of hard surface into soft landscape surface.
 - .4 Cap sleeve with removable plug or cover. Maintain plug in sleeve until such time as pipe or wire is ready to be installed.
 - .5 Bed sleeve as follows:
 - .1 Under walkways, 100mm of sand placed all around

- .2 Under driveways, roads and plazas, compacted base aggregate all around per materials shown on Drawings.
 - .6 Bury a piece of detectable metal on top of each end of sleeve to enable location of sleeve end by metal detector after burial.
 - .7 Stake location of each end of sleeve prior to backfilling such that top of stake is 300mm above finished grade and maintain. Label exposed end of stake with the word "sleeve".
 - .8 Record location of sleeve ends and label size of sleeve on Record Drawings.
 - .9 Remove sleeve stake after submission of Record Drawings.
- 3.31 Pipe and Fittings
- .1 Verify that all pipe, fittings, primer and cements are compatible for proper installation.
 - .2 Minimum burial depth and clearances for pipe and wire to be per Drawings.
 - .3 Do not locate open side of trench any closer than 300mm from hard surface or feature.
 - .4 Keep inside of pipe and outside of pipe ends clean at all times. Cap or plug open pipe ends to keep out dirt and debris.
 - .5 Cut PVC pipe ends at right angle to pipe length. Clean burrs prior to joining pipe and fittings.
 - .6 Do not apply cement or solvent weld pipe or fittings under wet or muddy conditions.
 - .7 Follow manufacturer's recommendations for use of pipe primer and cement.
 - .8 Immediately prior to joining pipe and fittings wipe contact surfaces clean with primer on clean rag.
 - .9 Apply light coat pipe of cement on inside of fitting and heavier coat on outside of pipe. Insert pipe into fitting

- and give a quarter turn to seat cement. Wipe excess cement from outside of pipe.
- .10 Make plastic to metal joints with plastic male adapters.
 - .11 Wrap male threads of threaded fittings with minimum 3 wraps of Teflon tape immediately prior to making connection.
 - .12 Flush all irrigation pipe fully to remove accumulation of dirt and debris prior to installation of heads, dripline, emitters and filters. Flush all laterals in a manner approved by the manufacturer to prevent clogging of screens, nozzles and emitters.
 - .13 Follow manufacturer's recommendations to install pipe in a manner that provides for expansion and contraction of pipe in trench.
 - .14 Conduct water service flow test and obtain approval of Contract Administrator prior to backfilling main line.
 - .15 Conduct mainline pressure test and HDPE pipe strap test and obtain approval of Contract Administrator prior to backfilling lines.
 - .16 Sidewall fusion of HDPE pipe is not acceptable.
 - .17 For HDPE pipe conduct HDPE pipe strap test obtain approval of Contract Administrator prior to backfilling HDPE pipe.
 - .18 Set mainlines and laterals on sand and backfill with sand to clearance limit shown on Drawings .
 - .19 For pipe in growing medium of landscaped areas backfill trench with growing medium and tamp in lifts to achieve compaction equal to the adjacent growing medium.
 - .20 For pipe in native soil, sub-surface fill, rocky soils and aggregate base or subbase material backfill remainder of trench with suitable non-sand material under 25mm in diameter and free of materials that could result in settling or damage to pipe or surface improvements.
 - .21 Install 14 gauge insulated trace wire (purple) on top of all mainline and lateral piping. Extend and fasten trace

wire into valve boxes, vaults and sleeves.

- .22 Install thrust blocks at all changes in direction of PVC pipe 2½" in diameter or greater, and for any change in direction of gasketed pipe.

3.32 Thrust Block

- .1 Place thrust block to support the pipe joints from separating, not to prevent the pipe from heaving. Do not cover top of pipe with concrete thrust blocking at change from a horizontal alignment to a vertical alignment.
- .2 For thrust blocks installed in disturbed soils (e.g. compacted backfill) increase the thrust block area by 50%.
- .3 Place 2 ply of 6mil polyethylene between pipe and thrust block.
- .4 Allow concrete to set before backfilling trench or pressurizing line.
- .5 Obtain approval from Contract Administrator prior to backfilling thrust block.

3.33 Sprinkler

- .1 Install per manufacturer's recommendations and in location shown on Contract Drawings.
- .2 Location of heads as illustrated on Contract Drawings is intended as a guide to layout of heads. Establish actual head locations in the field to ensure complete and adequate coverage of all areas to be irrigated and no overspray onto adjacent surfaces and improvements. Do not exceed head spacing shown on Contract Drawings.
- .3 Where obstructions or site improvements hinder or block head to head coverage advise Contract Administrator and determine best method to maximize coverage.
- .4 For head adjacent to hard surface or improvement set head as shown on Drawings.
- .5 For flat surfaces install head plumb to finished grade. For sloped surfaces install head perpendicular to half the grade of the slope.

- .6 Mount pop-up heads on triple swing-joint assembly. Connect bottom inlet of sprinkler to swing joint assembly, not side inlet. Adjust swing joint assembly to set head flush with finish grade. Tape threads of PVC fittings with Teflon tape and make hard-hand tight.
 - .7 Adjust arc, radius of coverage and flow at each sprinkler to achieve even head to head coverage of area to be irrigated, with minimum over spray onto other surfaces.
- 3.34 Dripline
- .1 Install per manufacturer's recommendations in location shown on Contract Drawings.
 - .2 Install pressure regulating module, low flow control valve and low flow filter at beginning of each drip zone.
 - .3 Do not install driplines or emitters of different flow rates on the same zone.
 - .4 Place dripline on prepared surface. Surface to be free of sharp rocks or other objects that may damage dripline. Surface to be at grade necessary for dripline to be at specified depth after placement of remainder of topsoil or growing medium.
 - .5 Placement of dripline by trenching using hand or mechanical methods permitted only if specified as such on Contract Drawings or upon written approval of Contract Administrator.
 - .6 Do not drive or operate equipment over exposed dripline.
 - .7 Make all zone connections and test manifold, lines and fittings for leaks prior to placement of topsoil or growing medium over manifold, dripline and emitters.
 - .8 Thoroughly flush each zone after installation and before beginning regular operation of drip zone.
- 3.36 Drip Irrigation for Planting Beds
- .1 For dripline in planting bed stake dripline using manufacturer's recommended stakes at 450mm on centre.

SUPPLEMENTARY SPECIFICATION CITY OF KELOWNA		IRRIGATION SYSTEM		SECTION 32 94 01S PAGE 36 OF 38
3.37	Drip Irrigation Turf Areas	for	.1	For turf area irrigated by dripline install temporary spray irrigation system as shown on Contract Drawings or approved Shop Drawing and maintain until end of Landscape Maintenance Period.
			.2	Operate both the temporary spray and dripline systems during the Landscape Maintenance Period in a coordinated way to both deliver optimum watering and to prove the performance of both systems. Temporary spray zones must meet efficiency standards and comply with head to head spacing policy.
3.38	Emitter/Bubbler		.1	Install per manufacturer's recommendations and as shown on Drawings.
			.2	Install pressure regulating module, low flow control valve and low flow filter at beginning of each emitter zone.
3.39	Hose Bib		.1	Install as shown on Drawings
3.40	Clean-up Restoration	and	.1	Remove all waste and debris resulting from irrigation installation from site.
			.2	Restore all disturbed surfaces to original condition and repair all trench settlement.
3.41	Instructions to Owner		.1	Instruct Owner in complete operating and maintenance procedures for irrigation system, including start-up, winterization, and programming.
			.2	Review Record Drawings and Operating Manual with Owner on site.
3.42	Maintenance General	-	.1	Inspect, operate, maintain and adjust irrigation system through the Landscape Maintenance Period until issuance of Certificate of Acceptance to ensure it operates as intended, including but limited to:
			.1	Adjust irrigation program to ensure survival, health and growth of the plant material and respond to soil conditions, climate and seasons of site

-
- .2 Clean sprinkler heads and adjust coverage to eliminate over watering, under watering and overspray onto adjacent surfaces
 - .3 Monitor and clean filtration equipment
 - .4 Restore grass areas, planting beds, hard surfaces and improvements affected by trench settlement and erosion
 - .5 Respond to requests from Contract Administrator for program adjustments, servicing, adjustments and repairs
- 3.43 Maintenance Winterization
- .1 During Landscape Maintenance Period be responsible for winterization of irrigation system at end of growing season and prior to onset of air temperatures below 0° Celsius. Be liable for any damage resulting from late or improper winterization.
 - .2 Request presence of Owner at winterization at least 5 days prior to proposed winterization.
 - .3 Winterization includes but is not limited to:
 - .1 Saturation of soil with water to a depth of 300mm to provide deep watering of all lawn areas, planting beds and tree pits
 - .2 Deactivation of controller
 - .3 Drainage and blow-out of entire irrigation system
 - .4 Contact water utility provider to determine if water meter is to be removed for winter. Remove and store water meter, or assist the water utility with removal of water meter, as directed by water utility.
- 3.44 Maintenance - Spring Start-up
- .1 During Landscape Maintenance Period be responsible for spring start-up of irrigation system at beginning of growing season or within 10 days of request for start-up from Owner. Be liable for any damage resulting from late or improper start-up.
 - .2 Ensure Owner is present for spring start-up. Request presence of Owner at least 5 days prior to proposed

start-up.

- .3 Prior to spring start-up contact water utility provider and examine service connection to determine if the water meter needs to be re-installed or re-activated. Re-install the water meter, or assist water utility with re-installation of the water meter, as directed by water utility.
- .4 Spring start-up includes but is not limited to:
 - .1 Checking and testing for leaks
 - .2 Cycling irrigation control program through all zones to ensure proper function and performance
 - .3 Checking and adjusting heads and emitters to achieve even coverage with minimum over spray onto other surfaces
 - .4 Testing of backflow prevention device. Submit test results to Contract Administrator and place copy of test results in irrigation cabinet
 - .5 Saturation of the soil with water to a depth of 300mm to provide deep watering of all lawn areas, planting beds and tree pits

3.45 Guarantee

- .1 Submit written guarantee, in approved form, stating that all work showing defects in materials, workmanship or operation will be repaired or replaced at no cost to Owner for a period of one year from date of Substantial Performance.
- .2 Guarantee includes the supply of labour, materials and equipment necessary for the repair and replacement of damaged or defective materials and workmanship. Guarantee also includes spring start-up, winterization, maintenance, necessary testing, program corrections or adjustments and restoration of settled trenches.
- .3 Guarantee will not apply to materials or workmanship damaged after Substantial Performance by causes beyond the Contractor's control, such as vandalism or abuse.

2.1 General

Replace .2 A list of approved waterworks products is provided by the City of Kelowna. See Council Policy 266.

2.2 Mainline Pipe, Joints and Fittings

.1 Ductile Iron Pipe

Add: .3 Wrap: Ductile iron pipe to be installed with a polyethylene encasement conforming to AWWA C104, unless the Consulting Engineer has arranged suitable testing of the soil conditions to satisfy the City Engineer that there is no risk of accelerated corrosion.

.14 Tapping Sleeves for Branch Connections 75 mm and Larger

Delete: .2 (not permitted)

Delete: .3 (not permitted)

2.3 Valves and Valve Boxes

.2 Mainline Gate Valves

Replace: .7 Acceptable manufacturers are as specified in the Approved Products List.

Replace: .3 Mainline Butterfly Valves: Butterfly valves: may only be installed on mains greater than 300 mm, to AWWA C504 Class 150B.

2.5 Service Connections, Pipe, Joints and Fittings

Replace: .1 Pipe diameter 19 mm to 50 mm to be Type K annealed copper, to ASTM B88M, and pipe diameter 25 mm to 50 mm may be Pressure Class 160 Polyethylene tubing, certified to CSA B137.1.

2.6 Hydrants

Replace: .2 Colour: All hydrants are to be painted in accordance with the City Supplement Standard Drawing SS-W4.

Add: .4 For hydrants not in service, place an orange bag over the entire hydrant, secured at the bottom with tape and labelled in black "Not In Service". Remove bag once the water main has been accepted by the Contract Administrator, City Engineer or Improvement District.

3.6 Pipe Installation

- Add to .1 Unless approved by the City Engineer or Improvement District, all pipe to be delivered from manufacturer with weather proof plugs/bagging to prevent contamination while being delivered and during storage. Pipe to remain this way until placed into trench and installed.
- Delete .6 (joint deflection not permitted for PVC pipe)
- Add .11 Metallic marking tape labeled WATERWORKS is to be placed above all pipes at a depth of 0.45m below finished grade in statutory rights-of-way.”

3.20 Disinfection, General

- Replace: .2 Disinfect and flush pipes and appurtenances in accordance with section 3.21, AWWA C651 and the City of Kelowna “Water Main Testing and Tie-In Procedure” (Schedule 5 Construction Specifications, Appendix ‘A’).
- Add: .3 Disinfect and flush water reservoirs and appurtenances in accordance with AWWA C652”.

3.23 Connections to Existing Mains

- Add: .2 Make connection (or disconnection) in presence of City Utility Personnel. Provide two full working days notice to schedule City Personnel. Obtain and authorize a City Third Party Work order prior to connection (or disconnection).

3.6 Pipe Installation

Add .14 Metallic marking tape labeled SANITARY SEWER is to be placed above all pipes at a depth of 0.45m below finished grade in statutory rights-of-way."

3.12 Leakage Testing General

Replace: .1 Upon completion of cleaning and flushing of each section, carry out leakage testing. Additional tests may be specified in the Supplementary Specification or be required as directed by the Contract Administrator. Test must include at a minimum, either:

.1 Water exfiltration test, or

.2 Low pressure air test.

3.18 Video Inspection

Add: .3 The Contract Administrator shall provide copies of all video inspection reports and digital files to the City of Kelowna once they have been reviewed, approved and confirmed to be in accordance with City of Kelowna requirements.

3.20 Connection to Existing Mains

Add: .3 Make connection (or disconnection) in presence of City Utility Personnel. Provide two full working days notice to schedule City Personnel. Obtain and authorize a City Third Party Work order prior to connection (or disconnection).

2.2 Pipe, Joints and Fittings

Delete: .1 (ductile iron pipe not permitted)

Add .2. .4 Forcemain pipe color is to be white and stenciled "Sanitary Forcemain". Metallic marking tape is to be placed in the bedding above the pipe."

2.3 Valves and Valve Boxes

.2 Gate Valves

Replace: .1 Locations of lubricated plug valves and resilient-seated valves as shown on Contract Drawings.

Delete: .2 (solid wedge valves not permitted)

3.5 Granular Bedding

Delete: .6 (ductile iron pipe not permitted)

3.6 Pipe Installation

Amend: .2 Delete "ductile iron pipe to AWWA C600 and C151".

3.11 Pipe Surround

Amend: .4 Delete "For ductile iron forcemain ensure hub joint occurs 0.3 m minimum to 0.5 m maximum from end of encasement".

3.15 Pressure Testing Procedures

Delete: .3 (ductile iron not permitted)

3.16 Connection to Existing Mains

Add: .3 Make connection (or disconnection) in presence of City Utility Personnel. Provide two full working days notice to schedule City Personnel. Obtain and authorize a City Third Party Work order prior to connection (or disconnection).

3.6 Pipe Installation

Add .14 Metallic marking tape labeled STORM SEWER is to be placed above all pipes at a depth of 0.45m below finished grade in statutory rights-of-way."

3.12 Inspection and Testing

Add: .4 The Contract Administrator shall provide copies of all video inspection reports and digital files to the City of Kelowna once they have been reviewed, approved and confirmed to be in accordance with City of Kelowna requirements.

3.14 Connection to Existing Mains

Add: .3 Make connection (or disconnection) in presence of City Utility Personnel. Provide two full working days notice to schedule City Personnel. Obtain and authorize a City Third Party Work order prior to connection (or disconnection).

City of Kelowna Supplemental Master Municipal Specifications	Manholes and Catch Basins	Section 33 44 01S Page 1 of 1 January, 2011
--	---------------------------------	---

2.1 Materials

Replace: .11 Catch basin leads to be minimum 200 mm diameter and of PVC DR35.

.15 Mortar:

Add: .3 Support concrete to be non-shrink type, minimum 20 MPa @ 28 days, maximum 10mm diameter aggregate.

Add: .24 Sulphate resistant concrete required where soil conditions warrant it.

3.3 Manhole Installation

Add: .19 Where manholes are to be installed in new or re-constructed roadways that require two lifts of asphalt, final adjustment of manhole frames and covers is to occur after first lift of asphalt is in place.

3.9 Adjusting Tops of Existing Units

Add: .6 Remove and replace existing "*sub-standard*" manhole frames and covers within work zone with new frames and covers in conformance with City Standard Drawings.

SCHEDULE 5 - CONSTRUCTION SPECIFICATIONS

APPENDIX A

WATER MAIN TESTING AND TIE-IN PROCEDURE

BL8847 and BL8993 both replaced Appendix A:

Water Main Testing and Tie-in Procedure

Prior to the completion of a tie-in of a newly constructed water main to the City of Kelowna Water System, the following procedures and tests must be performed, recorded and presented for acceptance:

Note: New water main and all appurtenances connected to it, to remain physically separated from existing water system during testing and flushing, and to remain separated until all test results have been reviewed and accepted by the City of Kelowna Water Utility. Testing against a valve is not permitted.

1. Pipe must be clean of any residual debris, foreign material, silt, etc. by means of flushing. For flushing procedures, refer to MMCD 31 11 01, 3.18 and AWWA C651.
2. Leakage and pressure testing to be performed in accordance with MMCD 31 11 01, 3.19 as well as AWWA C600 & M41 for ductile iron pipe, and C605 & M23 for PVC pipe.
3. Disinfection of water main to be in accordance with AWWA C651, MMCD 31 11 01 3.21. Results from this procedure must include actual concentration levels at 0 & 24 hours and must be from both ends of the pipe.
4. Flush water main to tanker truck or holding facility and dechlorinate the disinfection solution using sodium thiosulfate. Confirm that the solution has been neutralized prior to disposing to an approved location.
5. Test water main in accordance with AWWA C651 to confirm that no bacteria exists. Testing to include two consecutive sets of samples at least 24 hours apart, taken at both ends of the pipe, including all branches and at intervals in between as specified in AWWA 651. Tests required for the samples are; Total Coliform, Fecal Coliform, Background Bacteria, and a Chlorine Residual.

The Consultant or Contract Administrator to include the following results to the City of Kelowna Water Utility with the "Request for Water Main Tie-in" form, as prescribed by the City of Kelowna.

1. Copies of all test results including those from other companies that performed any of the tests.
2. A sketch or copy of a drawing showing the sections tested and the location of the tie-in(s).

Please note that water used for flushing and filling to be from an approved hydrant or from a City of Kelowna filling station. Ensure that adequate flushing of hydrant and hydrant lead takes place prior to using water. All water drawn from the City Water System to be done with approved backflow protection.

If the pipe is left idle for a period of more than 6 months, the line is to be flushed. Zero hour and 24 hour bacteria samples are to be taken. Repeat flushing and testing until water quality is satisfactory.

For information on procedures and testing, refer to the appropriate documents applicable as described above, or as listed below:

- ◆ Contract Documents
- ◆ Master Municipal Specifications (MMCD)
- ◆ City of Kelowna Subdivision & Servicing Bylaw
- ◆ City of Kelowna Water Regulation Bylaw
- ◆ AWWA standards
- ◆ Guidelines for Canadian Drinking Water Quality

2. STANDARD DRAWINGS

"Standard Detail Drawings" of the Master Municipal Specifications apply except where superseded by the City of Kelowna "Standard Detail Drawings" as set out herein or deleted as indicated on the Standard Drawing Index.

BL8847 and BL10481 amended the Drawing Index: CITY OF KELOWNA STANDARD DRAWINGS INDEX AND CROSS-REFERENCE TO MMCD				
MMCD Standard Drawings		City of Kelowna Standard Drawings		
Dwg.	Title	Comment	Dwg.	Title
	GENERAL DETAILS			
G1	General Legend for Contract Drawings	Deleted		<i>(Per City A-size Drawing Block)</i>
G2	Legend for Materials	MMCD	G2	Legend for Materials
G3	Legend for Street Light and Traffic Signal Drawings	Deleted		<i>(Future Amendment - Refer to Utility)</i>
G4	Utility Trench	Replaced	SS-G4	Utility Trench
G5	Pavement Restoration	Replaced	SS-G5	Pavement Restoration
G6	Concrete Encasement for Water Main/Sewer Separation	MMCD	G6	Concrete Encasement for Water Main/Sewer Separation
G7	Concrete Protection for Underground Utilities	MMCD	G7	Concrete Protection for Underground Utilities
G8	Pipe Anchor Blocks	MMCD	G8	Pipe Anchor Blocks
	STORM AND SANITARY SEWERS			
S1	Standard and Sump Manholes	Replaced	SS-S1a SS-S1b	Manholes Manhole Frame and Cover
S2	Standard Manhole Connection Details	Replaced	SS-S1a	Manholes
S3	Manhole Connection Details - Drop and Ramp Type	MMCD	S3	Manhole Connection Details - Drop and Ramp Type
S4	Inside Drop Manhole	MMCD	S4	Inside Drop Manhole
S5	Precast Riser Manhole	MMCD	S5	Precast Riser Manhole
S6	Sewer Clean-Out	Replaced	SS-S6	Clean-Out Detail (Temporary)
S7	Sanitary Sewer Service Connection	Replaced	SS-S7	Sanitary Sewer Service Connection
S8	Storm Sewer Service Connection	MMCD	S8	Storm Sewer Service Connection
S9	Inspection Chamber for 100 to 200 Sanitary Sewer Connection	Replaced	SS-S9	Inspection Chamber for 100 to 200 Sanitary Sewer Connection
S10	Inspection Chamber for 250 to 375 Storm Sewer Connection	MMCD	S10	Inspection Chamber for 250 to 375 Storm Sewer Connection

MMCD Standard Drawings		City of Kelowna Standard Drawings		
Dwg.	Title	Comment	Dwg.	Title
S11	Top Inlet Catch Basin	Replaced	SS-S11a SS-S11b SS-S11c	Catch Basin 900 mm diameter Catch Basin Castings Combined Side and Gutter Inlet Catch Basin - Top Slabs
S12	Lawn Drains	MMCD	S12	Lawn Drains
S13	Storm Sewer Inlet with Safety Grillage	MMCD	S13	Storm Sewer Inlet with Safety Grillage
S14	Concrete Block Endwall	MMCD	S14	Concrete Block Endwall
S15	Driveway Culvert with Concrete Block Endwalls	MMCD	S15	Driveway Culvert with Concrete Block Endwalls
		Added	SS-S50	Manhole Requirement for Services
		Added	SS-S51	Drainage Drywell
		Added	SS-S52	Drainage Drywell Installation
		Added	SS-S53	Pipe Perforation and Bedding Detail for Ground Water Recharge
		Added	SS-S54	Catch Basin Trapping Hood
		Added	SS-S55	Flow Control Chamber (with sediment grease trap)
		Added	SS-S56	IDF Curves
		Added	SS-S57	Riprap Design Chart
	WATERWORKS			
W1	Typical Thrust Block Arrangements	MMCD	W1	Typical Thrust Block Arrangements
W2a	Water Service Connection	Replaced	SS-W2	Water Service Connection
W2b	Water Service Connection	Replaced	SS-W2	Water Service Connection
W2c	Meter Installation for 19mm & 25mm Service Connections	Deleted		
W2d	Meter Installation for 38mm & 50mm Service Connections	Deleted		
W3	Gate Valve Installation	MMCD	W3	Gate Valve Installation
W4	Fire Hydrant Installation	Replaced	SS-W4	Hydrant
W5	Test Point Installation	MMCD	W5	Test Point Installation
W6	Air Valve Assemblies - 25 and 50 mm Valves	Replaced	SS-W6	Air Valve Assembly
W7	Air Valve Assembly - 100 mm Valve	Delete		
W8	Blow-Off for Water Main	Replaced	SS-W8a SS-W8b	Blow-Off (for mains 100mm & smaller) 100mm Blow-Off (for mains 150mm & larger)
W9	Blow - Down Chamber	MMCD	W9	Blow - Down Chamber
W10	Waterworks Chamber Drain	MMCD	W10	Waterworks Chamber Drain
		Added	SS-W50	Irrigation Service
		Added	SS-W51	U-Bend Detail (Pipe Crossing Conflict)

MMCD Standard Drawings		City of Kelowna Standard Drawings		
Dwg.	Title	Comment	Dwg.	Title
	CONCRETE AND MISCELLANEOUS DETAILS			
C1	Concrete Sidewalk, Infill and Barrier Curb	MMCD	C1	Concrete Sidewalk, Infill and Barrier Curb
C2	Concrete Sidewalk and Barrier Curb	MMCD	C2	Concrete Sidewalk and Barrier Curb
C3	Concrete Sidewalk and Roll-Over Curb	MMCD	C3	Concrete Sidewalk and Roll-Over Curb
C4	Concrete Curbs - Narrow Base	MMCD	C4	Concrete Curbs - Narrow Base
C5	Concrete Curbs - Wide Base	MMCD	C5	Concrete Curbs - Wide Base
C6	Concrete Median Curb and Interim Curbs	Replaced	SS-C6	Concrete Median Curb and Interim Curbs
C7	Driveway Crossing for Barrier Curbs	Replaced	SS-C7	Driveway Crossing for Barrier Curbs
C8	Wheelchair Ramp for Sidewalk, Infill and Barrier Curbs	MMCD	C8	Wheelchair Ramp for Sidewalk, Infill and Barrier Curbs
C9	Wheelchair Ramp for Sidewalk and Barrier Curbs	MMCD	C9	Wheelchair Ramp for Sidewalk and Barrier Curbs
C10	Concrete Walkway	Replaced	SS-R28	Walkway Gate
C11	Bicycle Baffle	Replaced	SS-R28	Walkway Gate
C12	Removable Restriction Post	Replaced	SS-R28	Walkway Gate
C13	Chain Link Fence for Walkway	MMCD	C13	Chain Link Fence for Walkway
C14	Handrail on Concrete Retaining Wall	MMCD	C14	Handrail on Concrete Retaining Wall
			SS-C50	Concrete Island Ramp
	ROAD WORKS			
R1	Paved Shoulders	MMCD	R1	Paved Shoulders
		Added	SS-R2	Lanes and Emergency and Private Access Roads
		Added	SS-R3	Local - Class 1 (18 m)
		Added	SS-R4	Local - Class 2 (15 m)
		Added	SS-R5	Collector - Class 1 (20 m)
		Added	SS-R6	Collector - Class 1 with Bike Lanes (22 m)
		Added	SS-R7	Collector - Class 2 (18 m)

MMCD Standard Drawings		City of Kelowna Standard Drawings		
Dwg.	Title	Comment	Dwg.	Title
	<u>ROAD WORKS</u> (Cont'd)			
		Added	SS-R8	Arterial - Class 1 Parkway, 4(6) Lanes (35 m)
		Added	SS-R9	Arterial - Class 1 Parkway, 2(4) Lanes (30 m)
		Added	SS-R10	Arterial - Class 1 Rural, 2(4) Lanes (30 m)
		Added	SS-R11	Arterial - Class 2 Residential, 4 Lanes (30 m)
		Added	SS-R12	Arterial - Class 2 Residential, One Way - 3 lanes (20 m)
		Added	SS-R13	Arterial - Class 2 Rural, 2 lane (20 m)
		Added	SS-R14	Arterial - Class 3 Town Centre 4 Lane (28 m)
		Added	SS-R15	Arterial - Class 3 Town Centre, One Way - 3 lanes (25 m)
		Added	SS-R16	Arterial - Class 3 - 2 lane (28 m)
		Added	SS-R17	Local Residential Cul-de-sac (15 m)
		Added	SS-R20	Left Turn Lane (Raised Median)
		Added	SS-R21	Left Turn Lane (Painted) and Two-Way Left Turn Lane
		Added	SS-R22	Curbed Driveway Widths
		Added	SS-R23	Concrete Drainage Swale Across Asphalt
		Added	SS-R24	Density Payment Adjustment Chart
		Added	SS-R25	Noise Mitigation Criteria
		Added	SS-R26	Hydrants and Poles Near Ditches
		Added	SS-R27	Street Name and Stop Sign Standard
		Added	SS-R28	Walkway Gate
		Added	SS-H1	Arterial Condition -A (Village Parkway)
		Added	SS-H2	Arterial Condition B (With 0.8 km Walking Distance of Village)
		Added	SS-H3	Arterial Condition C (Greater than 0.8 km Walking Distance of Village)
		Added	SS-H4	Village Collector Condition A (Retail/M.F. Fronting)
		Added	SS-H5	Village Collector Condition B (No Retail Fronting)
		Added	SS-H6	Collection Condition A (Development Both Sides)
		Added	SS-H7	Collector Condition B (Development One Side)
		Added	SS-H8	Collector Condition C - (No Development Either Side)

MMCD Standard Drawings		City of Kelowna Standard Drawings		
Dwg.	Title	Comment	Dwg.	Title
	ROAD WORKS (Cont'd)			
		Added	SS-H9	Minor Collector Condition A
		Added	SS-H10	Minor Collector Condition B
		Added	SS-H11	Village Local - Residential
		Added	SS-H12	Local Condition A (Development Both Sides)
		Added	SS-H13	Local Condition B (Development One Side)
		Added	SS-H14	Local Condition C (No Development Either Side)
		Added	SS-H15	Public Lane
	ELECTRICAL AND TRAFFIC SIGNAL DETAILS			<i>(Future Amendment - Refer to Utility)</i>
	LANDSCAPING AND IRRIGATION – 6 (B) Landscaping			
		Added	SS-L.01	Growing Medium - Lawn
		Added	SS-L.02	Growing Medium – Planting Bed
		Added	SS-L.03	Growing Medium - Boulevard
		Added	SS-L.04a	Tree – in Grass Open Space
		Added	SS-L.04b	Tree – in Planting Bed
		Added	SS-L.04c	Boulevard Tree – in Grass
		Added	SS-L.05a	Boulevard Tree – in Structural Soil (Plan)
		Added	SS-L.05b	Boulevard Tree – in Structural Soil (Section A-A')
		Added	SS-L.06a	Boulevard Tree – in Soil Cell (Plan)
		Added	SS-L.06b	Boulevard Tree – in Soil Cell (Section A-A')
		Added	SS-L.07	Root Barrier at Paving
	LANDSCAPING AND IRRIGATION – 6 (C) Irrigation			
		Added	SS-IR.01a	Backflow Prevention Assembly ¾"
		Added	SS-IR.01b	Backflow Prevention Assembly 1" to 2"
		Added	SS-IR.01c	Backflow Prevention Assembly 1" to 2"
		Added	SS-IR.01d	Backflow Prevention Assembly 2 1/2" to 4"
		Added	SS-IR.01e	Backflow Prevention Assembly 2 1/2" to 4"
		Added	SS-IR.02a	Irrigation Vault 1" to 2"
		Added	SS-IR.02b	Irrigation Vault ¾"
		Added	SS-IR.03	Irrigation Cabinet Double
		Added	SS-IR.04a	Trench Section w/o Sleeving
		Added	SS-IR.04b	Thrust Blocks
		Added	SS-IR.05a	Stand Alone Isolation Valve 50mm and Under
		Added	SS-IR.05b	Electric Control Valve 24VAC

MMCD Standard Drawings		City of Kelowna Standard Drawings		
Dwg.	Title	Comment	Dwg.	Title
		Added	SS-IR.06a	Control Zone Kit 25mm
		Added	SS-IR.06b	Control Zone Kit 38mm
		Added	SS-IR.07	Mainline Drain Valve
		Added	SS-IR.08a	Irrigation Value Box Small Size
		Added	SS-IR.08b	Irrigation Value Box Medium Size
		Added	SS-IR.08c	Irrigation Value Box Large Size
		Added	SS-IR.09	Wired Splice Box
		Added	SS-IR.10a	Sprayhead Sprinkler
		Added	SS-IR.10b	Rotor Sprinkler
		Added	SS-IR.11a	Dripline Header Assembly
		Added	SS-IR.11b	Root Watering System (Double)
		Added	SS-IR.11c	Tree Dripline
		Added	SS-IR.12a	Hydrant/Blow-Out Assembly 50mm
		Added	SS-IR.12b	Quick Coupler
		Added	SS-IR.12c	Lateral End Flush Valve
		Added	SS-IR.12d	Hose Bib
		Added	SS-IR.13	Temporary Boulevard Irrigation

Appendix 'E'

STANDARD DETAIL DRAWINGS

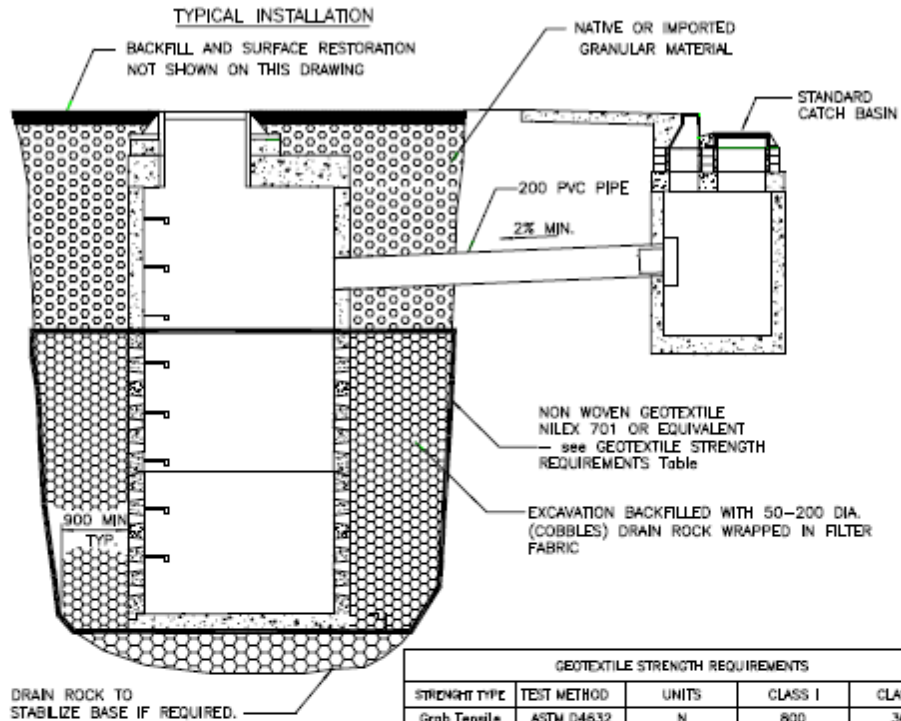

GEOTEXTILE STRENGTH REQUIREMENTS				
STRENGTH TYPE	TEST METHOD	UNITS	CLASS 1	CLASS 2
Grab Tensile	ASTM D4832	N	800	360
Puncture	ASTM D4833	N	370	200
Burst	ASTM D3786	kPa	1850	1030
Trapezoidal	ASTM D4533	N	260	130

1 Class 1: Geotextile installation where very coarse sharp angular aggregate is used
 Compaction > 95% Standard Proctor Maximum Dry Density (SPMDD)
 Depth of trench > 3.0

2 Class 2: Geotextile installation on smooth graded surfaces having no sharp angular aggregate.
 Compaction < 95% SPMDD

NOTES:

1. THE NUMBER AND SPACING OF DRAINAGE DRYWELLS MUST BE CALCULATED IN ACCORDANCE WITH CITY DESIGN CRITERIA AND WILL DEPEND UPON THE AREA DRAINED AND GROUND CONDITIONS. (SEE ALSO PIPE PERFORATION AND BEDDING DETAIL STANDARD DRAWING SS-S53).
2. FILTER FABRIC TO BE STRETCHED BELOW TOP BARREL SECTION AND REMOVED BY THE CONTRACTOR DURING THE FINAL INSPECTION.
3. DEPTH TO BE SPECIFIED WILL VARY DEPENDING UPON DRAINAGE REQUIREMENTS AND GROUND CONDITIONS. DEPTH TO WATER TABLE MUST BE SHOWN IF LESS THAN 3.6m. THERE IS NO NEED TO PLACE DRYWELLS BELOW LOW WATER TABLE.

FEB. 12/2010

DRAINAGE DRYWELL INSTALLATION

SS-S52

STANDARD DETAIL DRAWINGS

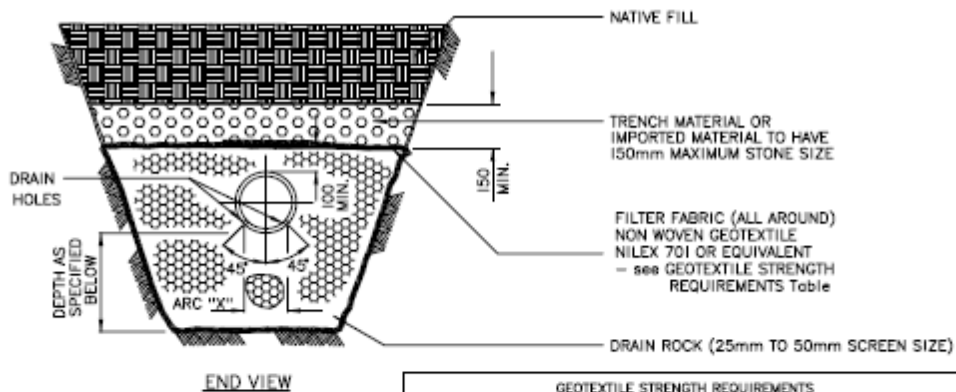

END VIEW

GEOTEXTILE STRENGTH REQUIREMENTS				
STRENGTH TYPE	TEST METHOD	UNITS	CLASS 1	CLASS 2
Grab Tensile	ASTM D4632	N	800	360
Puncture	ASTM D4833	N	370	200
Burst	ASTM D3786	kPa	1950	1030
Trapezoidal	ASTM D4533	N	260	130

1 Class 1: Geotextile installation where very coarse shape angular aggregate is used
 Compaction >95% Standard Proctor Maximum Dry Density (SPMDD)
 Depth of trench > 3.0

2 Class 2: Geotextile installation on smooth graded surfaces having no sharp angular aggregate.
 Compaction < 95% SPMDD

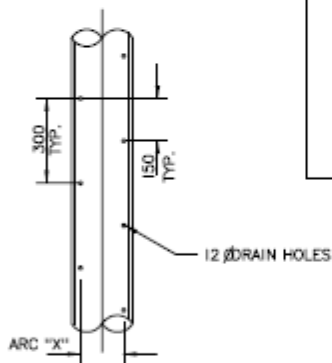

BOTTOM VIEW

NOMINAL PIPE DIAMETER	ARC "X" (BASED UPON AVERAGE O.D.)
200	160
250	200
300	240
375	290
450	350

NOTES:

1. PERFORATION SECTION APPLIES TO USE OF PVC PIPE.
2. FIELD PERFORATION OF PIPE SHALL BE TO THIS STANDARD. FACTORY PERFORATED PIPE MUST BE APPROVED BY THE CITY ENGINEER.
3. PROVIDE 0.5m MIN. FABRIC OVERLAP FOR LONGITUDINAL OR TRANSVERSE JOINTS IN FABRIC.
4. NUMBER OF DRYWELLS AND DEPTH OF DRAIN ROCK TO BE AS FOLLOWS:
 - a) FOR PERCOLATION RATE OF 0-15 MIN. PER 25mm
 - USE 5 PER HA.
 - USE 200mm DEPTH OF DRAIN ROCK UNDER PERF. PIPE
 - b) FOR PERCOLATION RATE OF 15-30 MIN. PER 25mm
 - USE 10 DRYWELLS PER HA.
 - USE 300mm DEPTH OF DRAIN ROCK UNDER PERF. PIPE
 - c) FOR PERCOLATION RATE OVER 30 MIN. PER 25mm, PERF. PIPE & DRYWELLS ARE NOT RECOMMENDED.

FEB. 12 / 2010

PIPE PERFORATION AND BEDDING DETAIL
FOR GROUND WATER RECHARGE

SS-S53

STANDARD DETAIL DRAWINGS

RAINFALL IDF CURVE FOR KELOWNA
(BASED ON RECORDING RAIN GAUGE DATA FOR THE PERIOD 1969-2004)

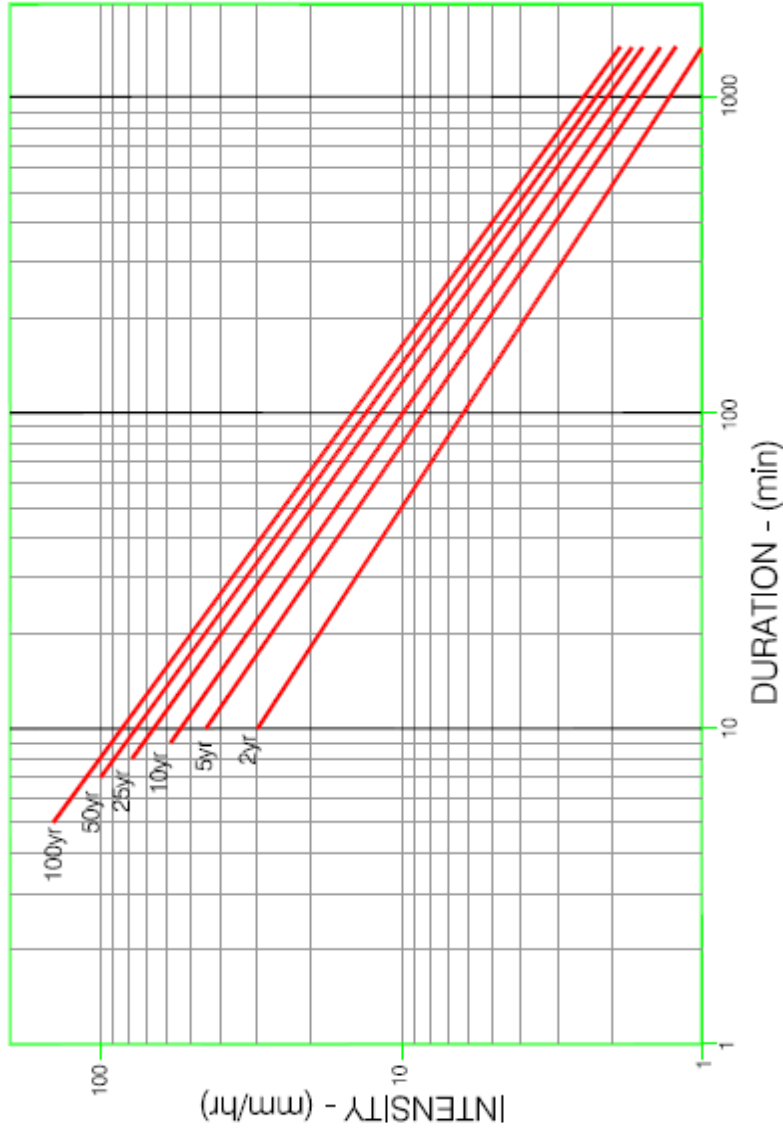

ATMOSPHERIC ENVIRONMENT SERVICE
ENVIRONMENT CANADA

P:\DRAFTING\STD-DWG\SUB\TAW\SS-S56

IDF CURVES

SS-S56

DATE: OCT.27/10

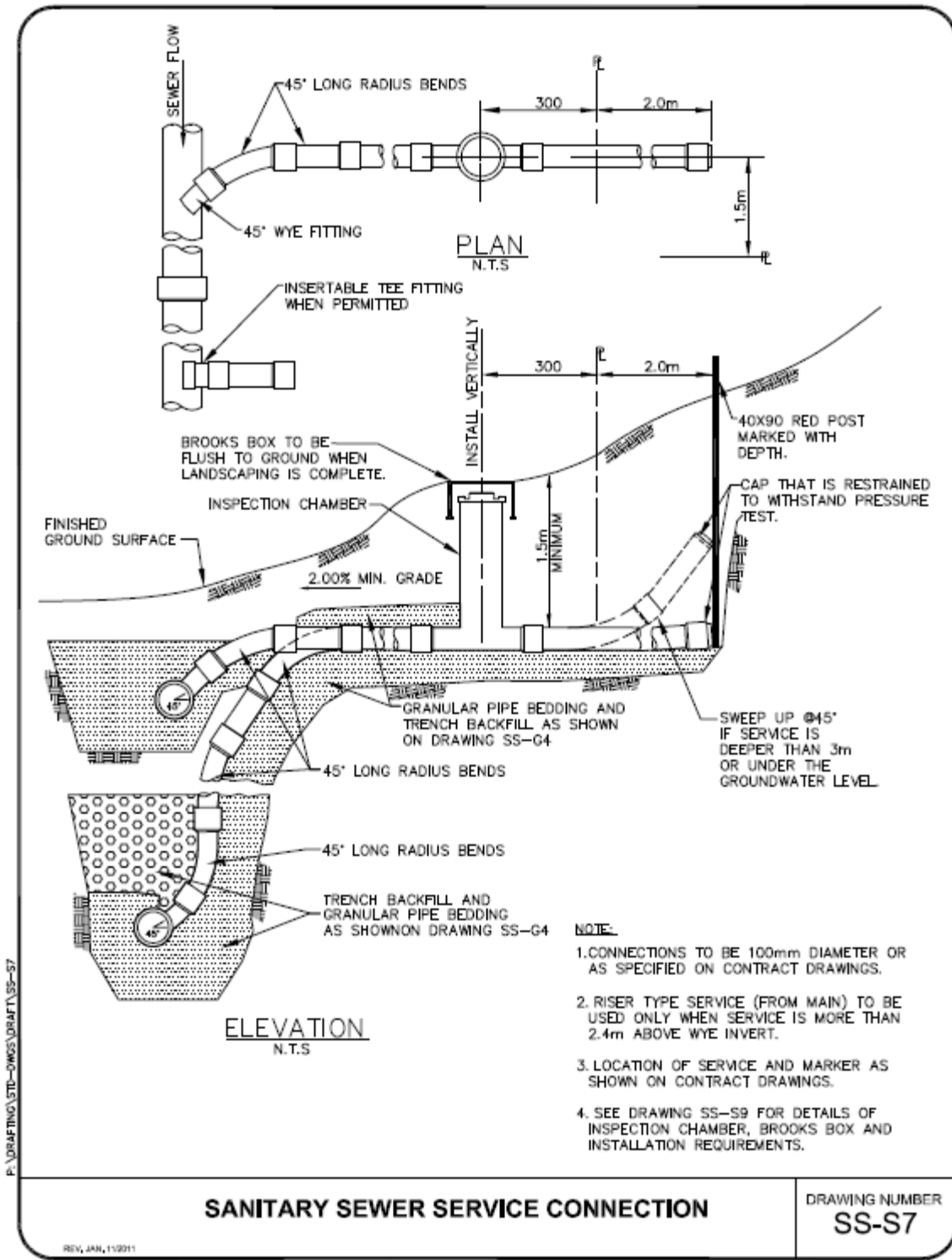

F:\DRAFTING\STD-CWGS\DRAWING\SS-S7

REV. JAN, 11/2011

SANITARY SEWER SERVICE CONNECTION

DRAWING NUMBER
SS-S7

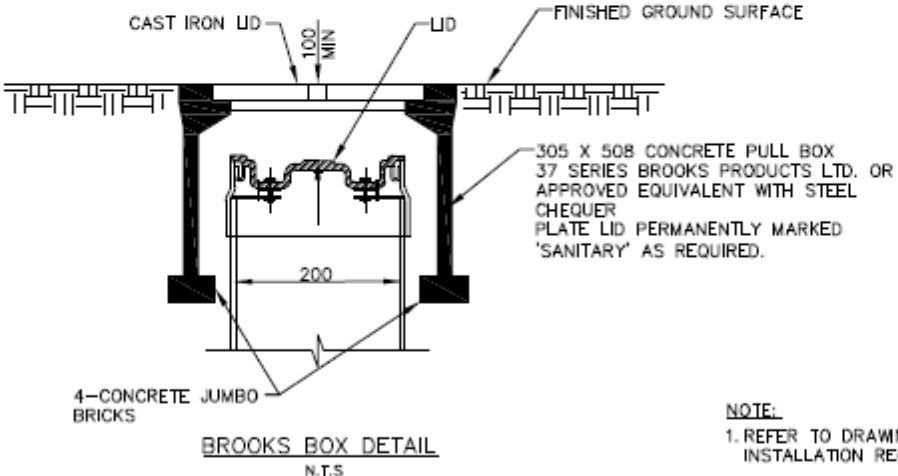
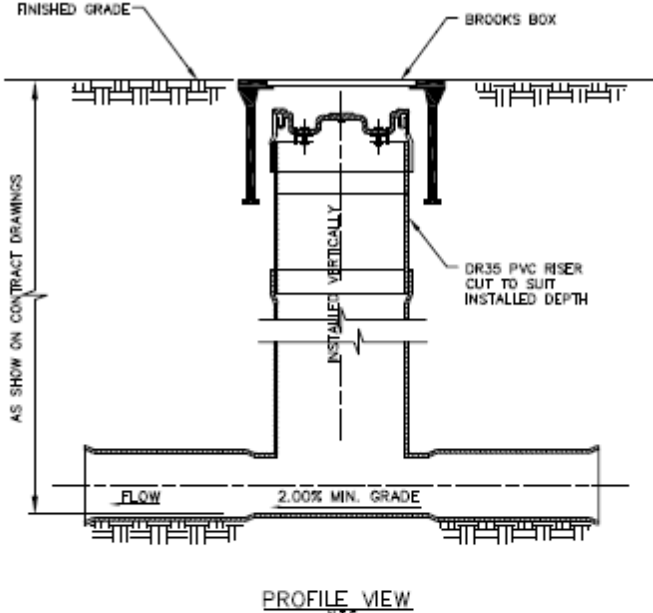
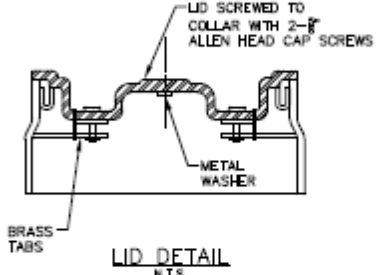
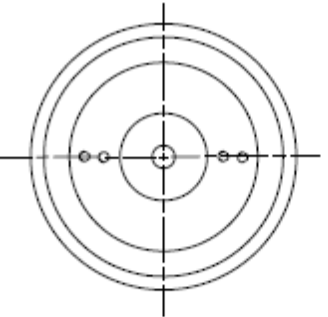
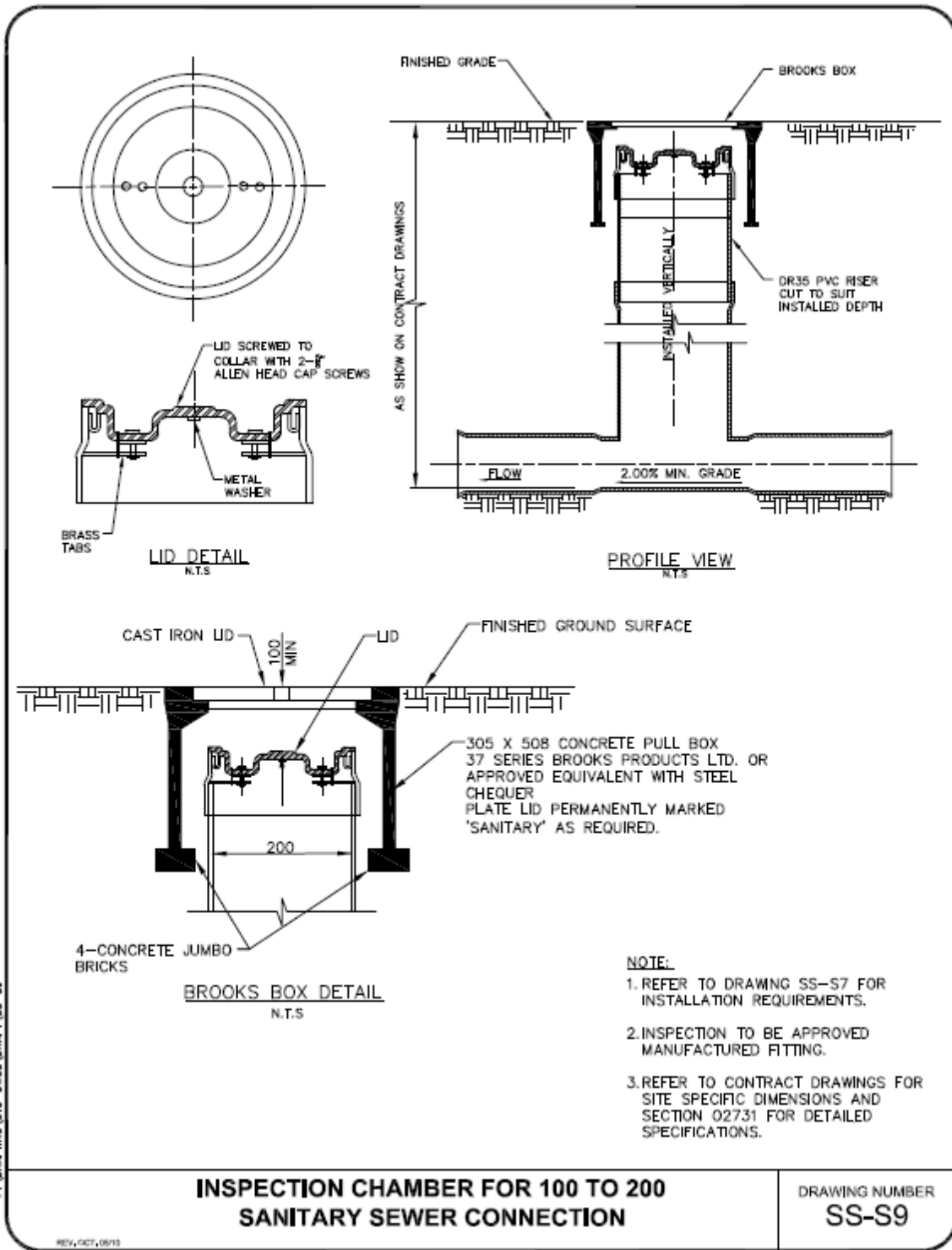

- NOTE:**
1. REFER TO DRAWING SS-S7 FOR INSTALLATION REQUIREMENTS.
 2. INSPECTION TO BE APPROVED MANUFACTURED FITTING.
 3. REFER TO CONTRACT DRAWINGS FOR SITE SPECIFIC DIMENSIONS AND SECTION 02731 FOR DETAILED SPECIFICATIONS.

**INSPECTION CHAMBER FOR 100 TO 200
SANITARY SEWER CONNECTION**

DRAWING NUMBER
SS-S9

P:\DRAFTING\STD-DWGSDRAFT\SS-S9

REV. OCT. 08/10